

AMANO®

PIX-28

Time Clock

Operation Manual



Proprietary Notice

This document contains proprietary information and such information may not be reproduced in whole or part without the written permission from:

Amano Cincinnati, Inc.
140 Harrison Ave.,
Roseland, New Jersey 07068.

Amano Cincinnati, Inc. reserves the right to make equipment changes and improvements, which may not be reflected in this document. Portions of this document may have been updated to include the latest hardware or firmware version, if applicable.

We recommend that this document be read in its entirety before any attempt is made to operate the equipment.

Table of Contents

Chapter 1: Overview	1
Specifications	1
External View	1
Rear Panel	2
LCD Display	2
Chapter 2: Getting Started	5
Removing the Cover & Packing Material	5
Mounting	6
Wall Mounting	6
Desktop Mounting	7
Make a Test Print	7
Ink Capacity Gauge	7
Chapter 3: Program Mode	9
Entering the Program Mode	10
Date (Month, Day and Year) Setting	10
Time (Clock) Setting	11
Daylight Saving Time Disable/Enable	11
Quick Set-Up Code	12
Other Options Menu	13
Print Style Using Symbol or Print Style Codes	14
Print Style Codes	14
Symbol Printing	15
Setting the Language	18
Print Direction	19
Setting the Auto Print	20
Leading Zero	21
Begin Daylight Saving Time	21
End Daylight Saving Time	22
Diagnostics	23
Chapter 4: Maintenance and Troubleshooting	25
Ribbon Cartridge Replacement	25
Error Messages	26

Specifications

Power Requirements:	PIX-28 Input: 16.5 VAC, 60Hz, 0.6A (Max.) AC Adapter: 120 VAC \pm 10%, 60Hz 230 VAC \pm 10%, 50Hz 240 VAC \pm 10%, 50Hz
Ambient Temperature:	-10°C~45°C (14°F~113°F)
Ambient Humidity:	10%~90% (no condensation)
Dimensions:	140mm x 150mm x 165mm 5.5in x 5.9in x 6.5
Weight:	1.8kg (4.2lbs.)
Environment:	Indoor use only; dust-free environment Keep out of direct sunlight

External View

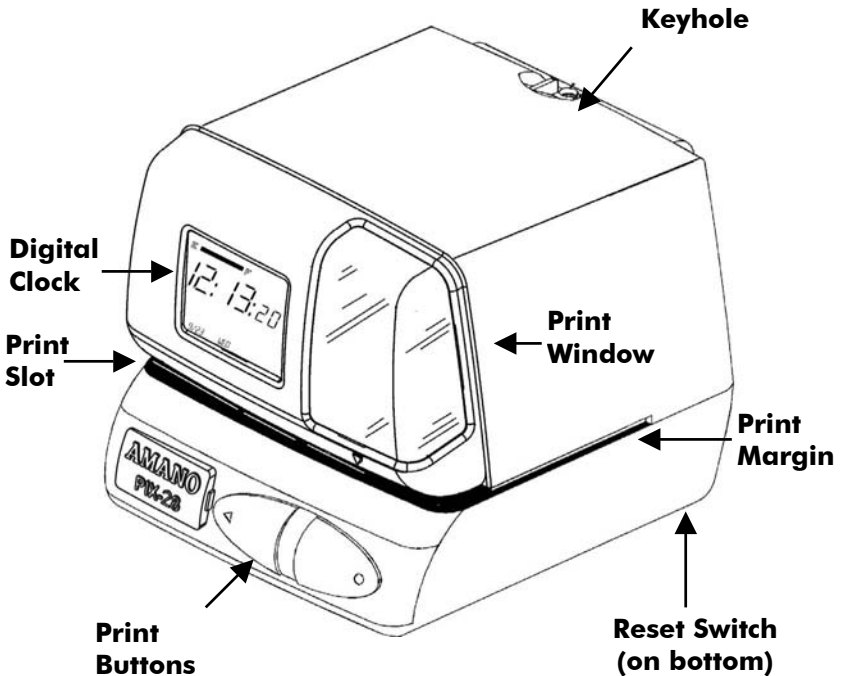

Rear Panel

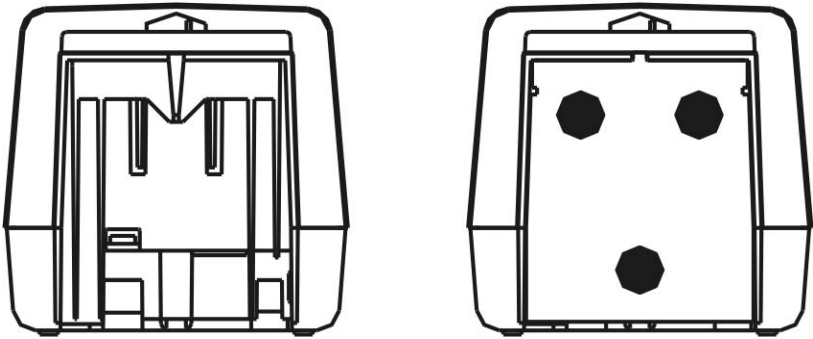

LCD Display

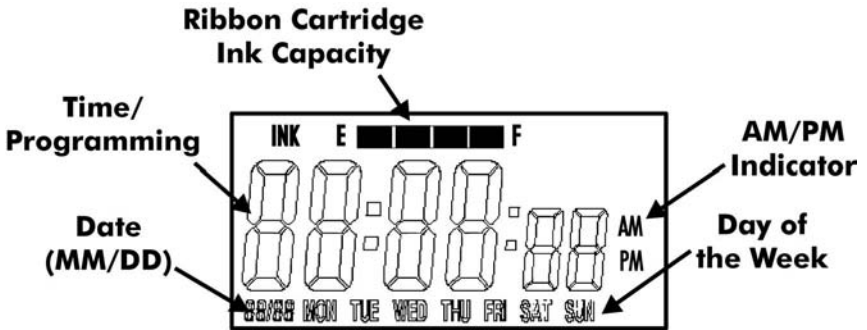

Description of Controls

Normally, the **Display Window** shows the date and time. When you use the Quick Set or Program Mode to change the settings of the PIX-28, the instructions to change the clock are shown in this window.

The buttons underneath the cover are used to navigate through the Quick Set and Program Mode to change the clock's settings.

CHANGE Button. Use this button to change the information shown on the display when you are in the Quick Set or Program Mode.

ENTER Button. When you are in the Quick Set or Program Mode, use this button to enter the setting shown on the display into memory.

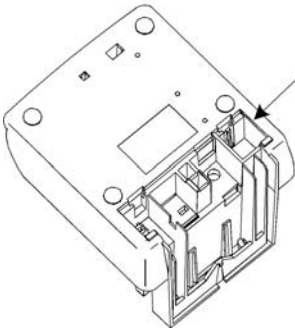

The RESET Button

The RESET Button is located on the bottom of the clock.

Chapter 2: Getting Started

Removing the Cover & Packing Material

You must remove the packaging spacers from the printer block and the Printer Carriage before attempting to use your PIX-28.

1. Insert the key provided and turn clockwise to open the case. Lift the cover to remove.
2. Lift the printer packing material and remove the Spacer A.
3. Remove Spacer B between the Ribbon Cartridge and the Printer Carriage.

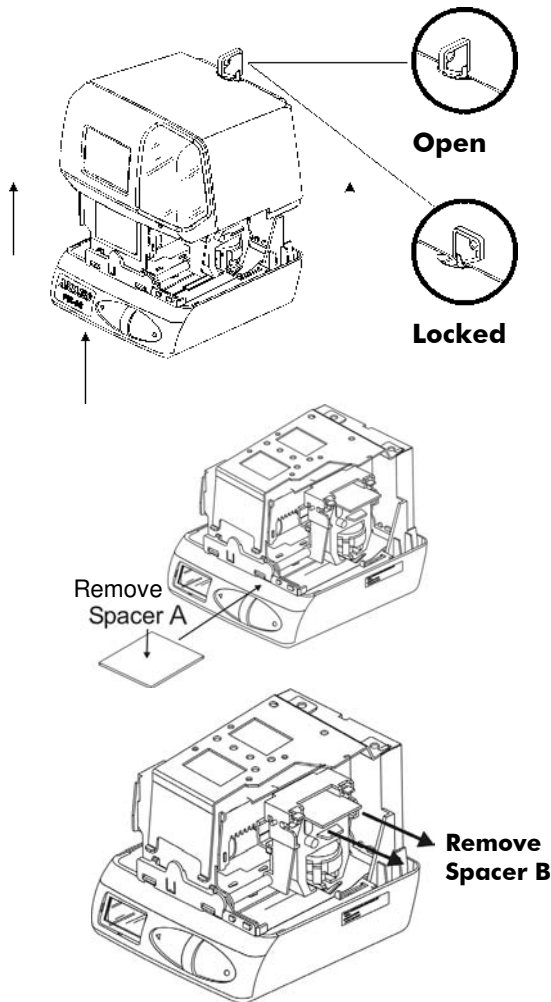

Mounting

When choosing a mounting location for your PIX-28, you should consider the following:

- The mounting surface or hardware must be capable of supporting the unit's weight, 2.5 kg (5.5 lbs).
- The area must be within the specified operating temperature range: -10°C~45°C (14°F~113°F), 10% ~90% Rh.
- The unit should be in close proximity to a power source or wall outlet.
- The following conditions should not exist:



Wall Mounting

1. Remove the cover.
2. With the clock facing you, remove the mounting bracket by pulling the top tabs (A) towards you, and then pushing the tabs down (see below).

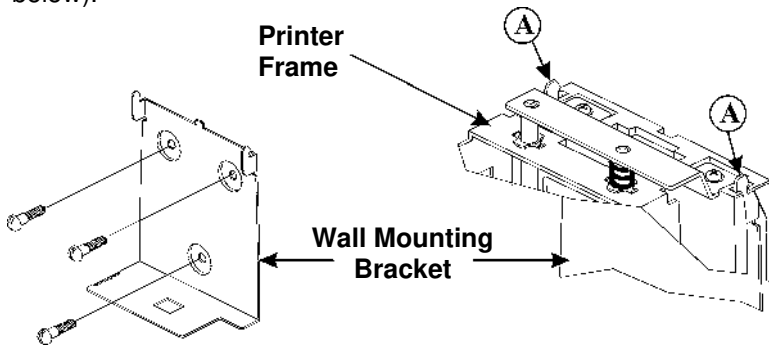

3. Securely mount the PIX mounting bracket on the wall using three #10 wood screws or equivalent.

- Place the PIX-28 on the mounting bracket by sliding the top tabs into the slots on each side of the case. Push the PIX-28 back and down against the mounting bracket until the PIX-28 snaps into place. Be careful not to pinch the power cord with the bracket. Installing the cover will secure the PIX-28 to the mounting bracket.

Desktop Mounting

The PIX-28 should be placed on a level surface with adequate ventilation.

Make a Test Print

- Make sure that there is power to the PIX-28.
- Insert a piece of paper or time card into the PIX-28. The clock will automatically print YEAR, MONTH, DATE and TIME with AM or PM.
'03 DEC 23 8:40PM
- If the imprint is satisfactory, the PIX-28 is ready for use.
- If you wish to change the time and/or print style on the PIX-28, enter into Program Mode. The next page gives instructions on programming the PIX-28 to fit your needs.

Ink Capacity Gauge

The LCD Display contains an Ink Capacity gauge. This gauge indicates the amount of ink remaining in the ribbon cartridge using four bar segments, from E (Empty) to F (Full).

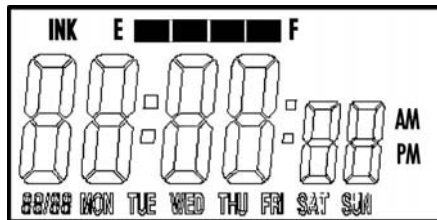

The PIX-28 calculates the ink capacity of the ribbon cartridge from the number of imprints made. As the ink capacity decreases, the bars in the gauge will disappear. If the ribbon reaches below 25% capacity, the "E", "F" and "INK" characters will blink until the ink counter is reset.

Chapter 3: Program Mode

Unlock and remove the cover. Locate the **PROGRAM**, **CHANGE**, **ENTER**, **HOUR**, and **MINUTE** buttons on top of the clock.

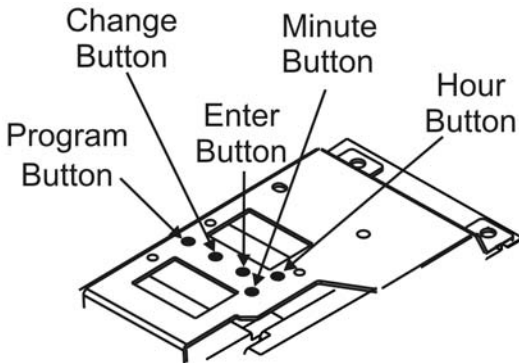

The **PROGRAM** button is used to enter and exit the Program Mode. If a program step is in the process of being changed when this button is pushed, the new information will not be saved.

The **CHANGE** button is used to change the information on the display.

The **ENTER** button is used to accept the information shown on the display and save it in memory or to enter a program mode.

The **HOUR** button is used to advance the hour in the display by increments of 1.

The **MINUTE** button is used to advance the minutes in the display by increments of 1.

The **RESET** button is located on the rear of the clock, underneath the unit. Pressing this button will clear any jams or errors.

Entering the Program Mode

1. To start the Program Mode, unlock and remove the cover.
2. Press and hold the PROGRAM button to access the Main Programming Menu, which consists of the following items:

Code	Menu	Function
P1	DATE	Year, Month, and Date settings
P2	Clock	Clock settings
P3	dLSE	Daylight Saving Time Enable/Disable
P4	Print	Quick Print Setup Codes
P5	Other	Other Options Menu

3. When DATE P1 flashes in the display, release the PROGRAM button.



Note: To exit the Program Mode at any time, press the Program button.

Date (Month, Day and Year) Setting

1. Enter the Program Mode. When DATE P1 flashes in the display, press the ENTER button.
2. Press the CHANGE button until the correct year appears, then press the ENTER button.
3. Press the CHANGE button until the correct day appears, then press the ENTER button.
4. Press the CHANGE button until the correct month appears, then press the ENTER button.
5. When the display flashes the correct month, date and year, press the ENTER button.
6. When the display flashes DATE P1, press the CHANGE button to move to Clock Settings, or press the PROGRAM button to exit the Program Mode.

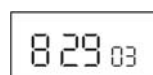
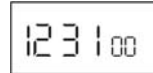

Time (Clock) Setting

1. Enter the Program Mode and press the CHANGE button. When **CLOC P2**, flashes in the display, press the ENTER button.
Note: Seconds are fixed at 00 and cannot be changed. The seconds will start incrementing from 00 when the ENTER button is pressed.
2. Press the CHANGE button until the correct minute appears, then press the ENTER button.
3. Press the CHANGE button until the correct hour and time of day appears, then press the ENTER button.
4. When the display flashes the correct time, press the ENTER button.
5. When the display flashes **CLOC P2**, press the CHANGE button to move to the Daylight Saving Time Setting or press the PROGRAM button to exit the Program Mode.



Daylight Saving Time Disable/Enable

Note: When this setting is set to ON, the clock's time will automatically change for DST. When this setting is set to OFF, the clock's time will not change for DST. The dates to begin and end DST are set in the Other Options Menu (See Page 13).

1. Enter the Program Mode and press the CHANGE button until **dLSt P3** flashes in the display. Press the ENTER button.
2. Press the CHANGE button to alternate between On and Off.
3. When the display flashes the correct setting, press the ENTER button.
4. When the display flashes **dLSt P3**, press the CHANGE button to move to the Quick Set-Up Code setting or press the PROGRAM button to exit the Program Mode.

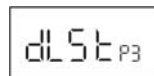
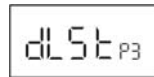

Quick Set-Up Code

Note: If you do not wish to use one of the Quick Set-Up Code settings, you may set an alternate style on the following page.

1. Enter the Program Mode and press the CHANGE button until $Prn \pm P4$ flashes in the display. Press the ENTER button.
2. The display will flash the current setting. Press the CHANGE button to scroll through each of the Quick Set-Up Code Settings.

Prnt P4

Pr-1

Code	Print Style
Pr-1	Year, Month, Date, 12 Hr, 60 th
Pr-2	Year, Month, Date, 24 Hr, 60 th
Pr-3	Year, Month, Date, 24 Hr, 100 th
Pr-4	Year, Month, Date, 24 Hr, 10 th
Pr-5	Day, 24 Hr, 100 th
Pr-6	2-Digit Year, Month, Date, 24Hr, 60 th , Seconds
Pr-7	4-Digit Year, Month, Date, 24Hr, 60 th , Seconds
Pr-8	Count, Month, Date, Year
Pr-9	Count, Date, Month, Year
Pr-0	Count, Date, Month, 24-Hr:60 th

3. When the display flashes the correct setting, press the ENTER button.
4. When the display flashes $Prn \pm P4$, press the CHANGE button to move to the Other Options menu, or press the PROGRAM button to exit the Program Mode.

Pr-5

Prnt P4

Other Options Menu

Note: If you do not wish to use one of the Quick Set-Up Code settings, you may set an alternate style on the following page.

1. Enter the Program Mode and press the CHANGE button until Othr P5 flashes in the display. Press the ENTER button.



2. The display will flash the first programming step in the Other Options Menu. Press the CHANGE button to advance through the menu selections.



Item	Print Direction
Prnt	Print style using Symbol or Print Style Codes
LANG	Language of the print out
Prdr	Print Direction (left or right hand)
APrt	Disable/Enable/Configure Auto Print option
ZEr 0	Disable/Enable Leading Zero in print out
bdLt	Daylight Saving Time Begin Date
EdLt	Daylight Saving Time End Date
DIAG	Diagnostics Menu

3. When the display flashes the correct selection, press the ENTER button.



4. After programming the selection, press the CHANGE button to return to the Other Options menu or press the PROGRAM button to exit the Program Mode.



Print Style Using Symbol or Print Style Codes

Note: The following options are to be used if you do not wish to use one of the Quick Set-Up Code settings on page 12.

Print Style Codes

Print Style Codes allow you to create an imprint based on a preset code for each of the four digits in the display.

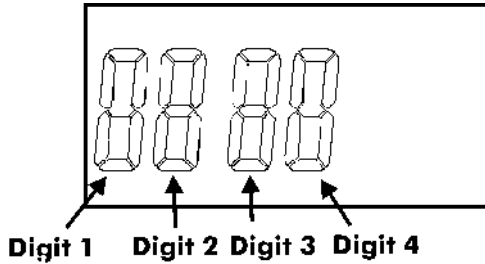

The codes and their meanings are as follows:

Digit 1	Digit 2	Digit 3	Digit 4*
0	0 = year, month, date	0 = Julian	0 = FILE
0	1 = 12Hr, 10ths	1 = day	1 = RCVD
0	2 = 24Hr, 10ths	2 = date	2 = SENT
0	3 = 12Hr, 20ths	3 = month, date	3 = FAX'D
4 = count	4 = 24Hr, 20ths	4 = date, month	4 = VOID
5 = left side printing	5 = 12Hr, 60ths	5 = day, date	5 = PAID
6 = right side printing	6 = 24Hr, 60ths	6 = date, day	6 = CFMD
0	7 = 12Hr, 100ths	7 = year, month, date	7 = APR'D
8 = seconds	8 = 24Hr, 100ths	8 = date, month, year	8 = CMPL'D
0	9 = 4 digit year	9 = month, date, year	9 = ORIGN

*Digit 4 becomes active when digit 2 = 0 and digit 3 = 7.

If you cannot locate the desired print style from the Quick Set-Up Code list, refer to the instructions for programming the imprint using Symbol Printing on page 15.

To create an imprint using Print Codes:

1. Enter the Program Mode and press the CHANGE button until $\text{Prnt} \text{P5}$ flashes in the display. Press the ENTER button. When $\text{Prnt} \text{P11}$ appears in the display, press the ENTER button.
2. Press the CHANGE button until Code Pr appears in the display, then press the ENTER button.
3. Press the CHANGE button until the desired number appears in the fourth position. Press the ENTER button.
4. Press the CHANGE button until the desired number appears in the third position. Press the ENTER button.
5. Press the CHANGE button until the desired number appears in the second position. Press the ENTER button.
6. Press the CHANGE button until the desired number appears in the first position. Press the ENTER button.
7. When the display flashes all four correct numbers, press the ENTER button.
8. When the display flashes $\text{Prnt} \text{P11}$, press the CHANGE button to move to the Language Setting or press the PROGRAM button to exit the Program Mode.

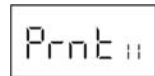
A rectangular display box containing the text "Prnt P5" in a monospaced font.A rectangular display box containing the text "Code Pr" in a monospaced font.A rectangular display box containing the text "6270" in a monospaced font.A rectangular display box containing the text "6281" in a monospaced font.A rectangular display box containing the text "6381" in a monospaced font.A rectangular display box containing the text "7381" in a monospaced font.A rectangular display box containing the text "7381" in a monospaced font.A rectangular display box containing the text "Prnt P11" in a monospaced font.

Symbol Printing

Symbol Printing allows you to create a custom imprint using Symbol Codes. Symbol Codes can be set in any order provided that the total length of the imprint does not exceed 150 dots or 99% of the maximum displacement (print length) of the print head. The print length of the print head is 152 dots or 35 mm (1.4").

To Create an Imprint Using Symbol Codes:

1. Enter the Program Mode and press the CHANGE button until $\text{Prnt} \text{P5}$ flashes in the display. Press the ENTER button. When $\text{Prnt} \text{P11}$ appears in the display, press the ENTER button.

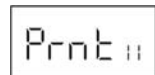
A rectangular display box containing the text "Prnt P5" in a monospaced font.

2. When CODE Pr appears in the display, press the CHANGE button.



3. When SYBL Pr appears in the display, press the ENTER button.



4. Press the CHANGE button until the character symbol you want to print appears, then press the ENTER button. The Symbol Codes are as follows:



Code	Character	Length
YEAR 2d	2-Digit Year	25 = 16.45%
mm on th	Month	30 = 19.74%
dM-E	Date	20 = 13.16%
dAY	Day	20 = 13.16%
JLAN	Julian Date	30 = 19.74%
10th 12	12 Hr. and 10th/Hr.	49 = 32.24%
60th 12	12 Hr. and 60th/Hr.	59 = 38.82%
100th 12	12 Hr. and 100th/Hr.	59 = 38.82%
10th 24	24 Hr. and 10th/Hr.	35 = 23.03%
60th 24	24 Hr. and 60th/Hr.	45 = 29.61%
100th 24	24 Hr. and 100th/Hr.	5 = 29.61%
SLSh	Slash (/)	10 = 6.58%
dASh	Dash (-)	07 = 4.61%
SPCE	Space ()	03 = 1.97%
YEAR 4d	4-Digit Year	28 = 14.00%
blac	Block (■) delimiter use between fields.	10 = 6.58%
SY-1	RCV'D	43 = 28.29%
SY-2	SENT	40 = 26.32%
SY-3	FAX'D	43 = 28.29%
SY-4	VOID	40 = 26.32%
SY-5	PAID	40 = 26.32%
SY-6	FM'D	43 = 28.29%
SY-7	APR'D	43 = 28.29%
SY-8	CMPL'D	53 = 34.87%
SY-9	ORIGN	50 = 32.89%
SY-0	FILE	40 = 26.32%
End	End of File	-

Code	Character	Length
dAd	Add a Character	-
dEL	Delete a Character	-

The table lists examples of the many imprints that can be created using Symbol Printing:

Print Style	Example	Code to Enter
DAY,12Hr,60th/Hr	FRI PM 1:45	dRY•SPCE•60th 12
DAY,24Hr,60th/Hr	FRI 13:45	dRY•SPCE•60th 24
DAY,24Hr,10th/Hr	FRI 13.7	dRY•SPCE•10th 24
DAY,24Hr,100th/Hr	FRI 13.75	dRY•SPCE•100th 24
DATE,12Hr,60th/Hr	13 PM 1:45	dRCE•SPCE•60th 12
DATE,24Hr,60th/Hr	13 13:45	dRCE•SPCE•60th 24
DATE,24Hr,10th/Hr	13 13.7	dRCE•SPCE•10th 24
DATE,24Hr,100th/Hr	13 13.75	dRCE•SPCE•100th 24
MONTH,DATE,12Hr,60th/Hr	APR13 PM 1:45	month•SPCE•dRCE•SPCE•60th 12
MONTH,DATE,24Hr,60th/Hr	APR13 13:45	month•SPCE•dRCE•SPCE•60th 24
MONTH,DATE,24Hr,10th/Hr	APR13 13.7	month•SPCE•dRCE•SPCE•10th 24
MONTH,DATE,24Hr,100th/Hr	APR13 13.75	month•SPCE•dRCE•SPCE•100th 24
YEAR,MONTH,DATE,12Hr,60th/Hr	95 APR13 PM 1:45	YEAR•2d•SPCE•month•SPCE•dRCE•SPCE•60th 12
YEAR,MONTH,DATE,24Hr,60th/Hr	95 APR13 13:45	YEAR•2d•SPCE•month•SPCE•dRCE•SPCE•60th 24
YEAR,MONTH,DATE,24Hr,10th/Hr	95 APR13 13.7	YEAR•2d•SPCE•month•SPCE•dRCE•SPCE•10th 24
YEAR,MONTH,DATE,24Hr,100th/Hr	95 APR13 13.75	YEAR•2d•SPCE•month•SPCE•dRCE•SPCE•100th 24
YEAR,MONTH,DATE,SYMBOL1	95 APR13 RCV'D	YEAR•2d•SPCE•month•SPCE•dRCE•SPCE•SY-1
YEAR,MONTH,DATE,SYMBOL2	95 APR13 SENT	YEAR•2d•SPCE•month•SPCE•dRCE•SPCE•SY-2
YEAR,MONTH,DATE,SYMBOL3	95 APR13 FAX'D	YEAR•2d•SPCE•month•SPCE•dRCE•SPCE•SY-3
YEAR,MONTH,DATE,SYMBOL4	95 APR13 PAID	YEAR•2d•SPCE•month•SPCE•dRCE•SPCE•SY-4

- Continue to assign codes until you have finished.
- Press the CHANGE button until the End code flashes, then press the ENTER button.
- When the display flashes Prnt P11, press the CHANGE button to move to the Language Setting or press the PROGRAM button to exit the Program Mode.



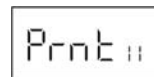

Setting the Language

The PIX-28 can be set to print months, days of the week, and certain keywords in one of the following (6) languages: English (Default), Spanish, French, Portuguese, Italian, German and Common (Numeric with Julian Calendar). The language imprints are as follows:

Imprint	English	Spanish	French	Portuguese	Italian	German
Monday	MO	LU	LU	SG	LU	MO
Tuesday	TU	MA	MA	TR	MA	DI
Wednesday	WE	MI	ME	QU	ME	MI
Thursday	TH	JU	JE	QI	GI	DO
Friday	FR	VI	VE	SX	VE	FR
Saturday	SA	SA	SA	SB	SA	SA
Sunday	SU	DO	DI	DO	DO	SO
January	JAN	ENE	JAN	JAN	GEN	JAN
February	FEB	FEB	FEV	FEV	FEB	FEB
March	MAR	MAR	MAR	MAR	MAR	MAR
April	APR	ABR	AVR	ABR	APR	APR
May	MAY	MAY	MAI	MAI	MAG	MAI
June	JUN	JUN	JUN	JUN	GIU	JUN
July	JUL	JUL	JUL	JUL	LUG	JUL
August	AUG	AGO	AOU	AGO	AGO	AUG
September	SEP	SEP	SEP	SET	SET	SEP
October	OCT	OCT	OCT	OUT	OTT	OKT
November	NOV	NOV	NOV	NOV	NOV	NOV
December	DEC	DIC	DEC	DEZ	DIC	DEZ
received	RCV'D	RCBDO	RECU	RCBDO	RICEV	EING
sent	SENT	ENVDO	ENV	ENVDO	SPED	AUSG
faxed	FAX'D	FAX	FAXE	FAX	FAX	FAX
void	VOID	ANLDO	ANNUL	ANUL	ANNUL	LAGER
paid	PAID	PGADO	PAYE	PAGO	PAGA	BEZ
confirmed	CFM'D	CONFDO	CONF	CONF	CONF	EMPF
approved	APR'D	APBDO	APPR	APRV	APPR	BEST
completed	CMPL'D	TRMDO	TERM	TERM	COMPL	ABGES
origin	ORIGN	ORIGN	ORIG	ORIG	ORIG	ORIG
file	FILE	ARCH	FICH	ARQV	FILE	AKTE

To Set the Language:

1. Enter the Program Mode and press the CHANGE button until **0t hr P5** flashes in the display. Press the ENTER button.
2. Press the CHANGE button until **LAN9 12** flashes in the display. Press the ENTER button. The language codes are as follows:

0t hr P5

LAN9 12

Language	Code
English	En9 L1
Spanish	SPn L2
French	Frn L3
German	9Er L4
Italian	It9 L5
Portuguese	Ptg L6
Common	Conn L7

3. Press the CHANGE button to advance through the list of languages. Press the ENTER button to make a selection.
4. When the display flashes **LAN9 12**, press the CHANGE button to move to the Print Direction Setting, or press the PROGRAM button to exit the Program Mode.

Frn L3

LAN9 12

Print Direction

Printing orientation can be programmed for Right or Left Side (Edge) (time) card printing. The default setting is Left Side Printing. If you wish to change this setting, perform the following:

1. Enter the Program Mode and press the CHANGE button until **0t hr P5** flashes in the display. Press the ENTER button.
2. Press the CHANGE button until **Pr dr 13** flashes in the display. Press the ENTER button.
3. Press the CHANGE button until the correct print direction **r9ht** (Right Side) or **LEf 1** (Left Side) flashes in the display, then press the ENTER button.
4. When the display flashes **Pr dr 13**, press the CHANGE button to move to the Auto Print Setting, or press the PROGRAM button to exit the Program Mode.

0t hr P5

Pr dr 13

r9ht

Pr dr 13

Setting the Auto Print

Media (time cards, etc.) are manually inserted into the PIX-28 and aligned. The PIX-28 can be set to print the imprint on media manually using the Print button (single prints or multiple prints) or automatically. To do so, perform the following:

1. Enter the Program Mode and press the CHANGE button until 02hr P5 flashes in the display. Press the ENTER button.
2. Press the CHANGE button until APrt 14 flashes in the display. Press the ENTER button.
3. Press the CHANGE button until the desired code appears on the display, and then press the Enter button. The Auto Print codes are as follows:

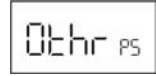



Code	Mode	Description
P on	Auto Print	Will automatically print a single print when media are inserted.
OFF	Manual Print	Requires you to use the PRINT button when printing.
P5 on	Precision Print	Enables you to print multiple or consecutive prints when holding down the PRINT button.

4. When the display flashes APrt 14, press the CHANGE button to move to the Leading Zero Setting, or press the PROGRAM button to exit the Program Mode.



Leading Zero

The PIX-28 can include a leading zero on the imprint before single digit times and dates. (For example, DEC. **06**, **08**:00). As shipped, this feature is disabled, but can be enabled for your application. To enable/disable this feature, perform the following:

1. Enter the Program Mode and press the CHANGE button until 01hr P5 flashes in the display. Press the ENTER button.
2. Press the CHANGE button until 2Er 15 flashes in the display. Press the ENTER button.
3. Press the CHANGE button until the desired setting OFF (Disable) or ON (Enable) flashes in the display, then press the ENTER button.
4. When the display flashes 2Er 15, press the CHANGE button to move to the Begin Daylight Saving Time Date Setting, or press the PROGRAM button to exit the Program Mode.



Begin Daylight Saving Time

This setting defines the start or beginning date of Daylight Saving Time. Once set, it will automatically adjust every year. You will only need to program it once. Daylight Saving Time is enabled/disabled in the Main Programming Menu.

1. Enter the Program Mode and press the CHANGE button until 01hr P5 flashes in the display. Press the ENTER button.
2. Press the CHANGE button until bdl 15 flashes in the display. Press the ENTER button.
3. Press the CHANGE button until the correct year that Daylight Saving Time is set to begin appears in the display, then press the ENTER button.
4. Press the CHANGE button until the correct day that Daylight Saving Time is set to begin appears in the display, then press the ENTER button.
5. Press the CHANGE button until the correct month that Daylight Saving Time is set to begin appears in the display, then press the ENTER button.

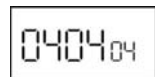
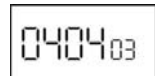
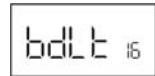

6. When the display flashes the correct year, month and date, press the ENTER button.
7. When the display flashes **bdL 16**, press the CHANGE button to move to the End Daylight Saving Time Date Setting, or press the PROGRAM button to exit the Program Mode.

End Daylight Saving Time

This setting defines the end date of Daylight Saving Time. You will only need to program it once. Once set, it will automatically adjust every year. Daylight Saving Time is enabled/disabled in the Main Programming Menu.

1. Enter the Program Mode and press the CHANGE button until **02hr P5** flashes in the display. Press the ENTER button.
2. Press the CHANGE button until **EdL 17** flashes in the display. Press the ENTER button.
3. Press the CHANGE button until the correct year that Daylight Saving Time is set to end appears in the display, then press the ENTER button.
4. Press the CHANGE button until the correct day that Daylight Saving Time is set to end appears in the display, then press the ENTER button.
5. Press the CHANGE button until the correct month that Daylight Saving Time is set to end appears in the display, then press the ENTER button.
6. When the display flashes the correct year, month and date, press the ENTER button.
7. When the display flashes **EdL 17**, press the CHANGE button to move to Diagnostics, or press the PROGRAM button to exit the Program Mode.

Diagnostics

The Diagnostics menu contains the following options:

Soft d1	Displays the firmware version of your PIX-28.
Lcd d2	Turns all segments of the display on to verify proper LCD operation.
nPrnt d3	Displays the number of prints. Maximum memory 999,999 print counts. Can be reset using theClr d4 item.
Clr d4	<u>Clear Menu</u> Code 13: Resets cumulative number of punches printed by preset Pr-8. Code 22: Resets ribbon capacity gauge. Code 32: Clears memory (except cumulative number of punches).

To Use the Diagnostics Menu:

1. Enter the Program Mode and press the CHANGE button until **Prnt P5** flashes in the display. Press the ENTER button.
2. Press the CHANGE button until **DIAG I8** flashes in the display. Press the ENTER button.
3. **Soft d1** will flash in the display. To advance to the next Diagnostics menu selection, press the CHANGE button. If you wish to check the firmware version of your PIX-28, press the ENTER button. The version number will appear in the display. To clear the display, press the ENTER button. The display will advance to the LCD Test item.
4. To test the LCD, press the CHANGE button until **Lcd d2** flashes in the display. Press the ENTER button. All the segments of the LCD will turn on. To clear the display, press the ENTER button. The display will advance to the Print Counter.
5. To check the number of prints performed, press the CHANGE button until **nPrnt d3** flashes in the display. Press the ENTER button. The number of prints will appear in the display. To clear the display, press the ENTER button.

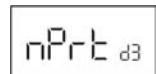
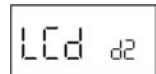

6. To enter the clear menu, press the CHANGE button until **CLr d4** flashes in the display. Press the ENTER button.

A rectangular LCD display showing the text "CLr d4" in a digital font.

7. Choose the Clear Menu code you wish to modify from the table above. Press the CHANGE button to enter the last digit of the code and ENTER to accept it. Press the CHANGE button to enter the first digit of the code and ENTER to accept it. When the display flashes the correct code, press ENTER.

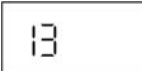
A rectangular LCD display showing the number "13" in a digital font.

8. If the code is incorrect, the display will flash **CLr d4**. Press the ENTER button to try again.

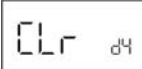
A rectangular LCD display showing the text "CLr d4" in a digital font.

9. If the code is correct, the display will flash **d1R9 18**. Press the CHANGE button until **d1R P5** flashes in the display, or press the PROGRAM button to exit the Program Mode.

A rectangular LCD display showing the text "d1R9 18" in a digital font.

Chapter 4: Maintenance and Troubleshooting

Ribbon Cartridge Replacement

1. Remove the cover.
2. Pull the two release tabs upward.

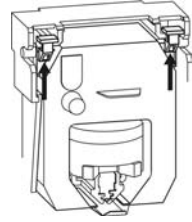

3. While holding the release tabs in an upward position, pull the ribbon cassette out of the cradle.

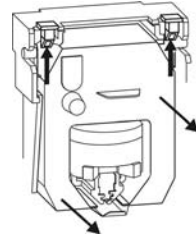

Note: If the print mechanism is down and a piece of paper cannot be inserted, press the RESET button to move the carriage up. This will make the ribbon installation easier.

4. Insert a new ribbon between the ribbon guide and the printer head as shown. Be sure to mount the ribbon between the printer head and ribbon guide as arrows illustrate.

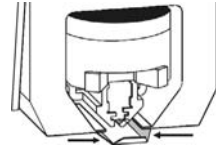

5. Turn the knob on the cassette clockwise one turn to take up any slack in the ribbon.

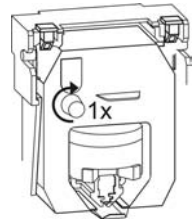

6. Replace the cover.
7. Reset the INK indicator by pressing the CHANGE and ENTER buttons at the same time.
8. Check the printing quality to confirm that you have installed the ribbon properly.



Error Messages

Error Code	Cause
Pr _L E1	Home sensor, motor carriage stuck
Pr _L E2	Timing sensor, carriage stuck
Pr _L E3	Home sensor
Pr _L E4	Carriage stuck
Pr _L Er	General print error
dL _L	Daylight Saving Time Program

For error messages Pr_L E1 through Pr_L Er, turn off the power before checking to see that the carriage is not stuck or jammed. Also, check to see that the ribbon cables are in good condition. After clearing any jams, restore the power and press the RESET button. Contact your Amano Cincinnati representative for assistance.

The dL_L error message signifies that an attempt was made to get into the Program mode during the Daylight Saving Time changeover one-hour lockout. Wait one hour and you will be able to program the clock.



Central Time Clock

Since 1931

5-23 50th Avenue
Long Island City, NY 11101
P: 718-784-4900
F: 718-472-9491
www.centraltimeclock.com