

AMANO[®]

CP-3000

Electronic Time Recorder

User's Guide



PROPRIETARY NOTICE

This document contains proprietary information and such information may not be reproduced in whole or in part without the written permission from:

Amano Cincinnati, Inc.,
140 Harrison Avenue
Roseland, New Jersey, 07068

Amano Cincinnati, Inc. reserves the right to make equipment changes and improvements which may not be reflected in this document. Portions of this document may have been updated to include the latest hardware or firmware version, if applicable.

We recommend that this document be read in its entirety before any attempt is made to operate the equipment.

**For more information about Amano's complete product line
visit our web site at
<http://www.amano.com>**

Chapter 1: Introduction	1
External View	1
Other Components	1
Features	1
Front Panel Description	2
Chapter 2: Getting Started	3
Top Cover	3
Removal	4
Installation	4
Placement/Location	5
Desktop Installation	5
Wall Mounting	6
External Signal Connections	8
Connecting the Battery	10
Initialization and Reset	12
Initialization	12
Reset (All Clear)	13
Power Connection	14
Chapter 3: Time Cards	15
Making a Test Print	15
Card Dimensions	16
Card Color	17
Time Card Settings	17
Card Type Setting	17
Side Margin (Sm) Adjustment	18
Bottom Margin (Bm) Adjustment	19
Card Thickness Adjustment	20
Card Width Adjustment	21
Chapter 4: Programming	23
Introduction	23
General Programming Guidelines	23
Entering Program Mode	23
Entering and Saving Values	24
Scrolling Through the Program Mode	24
Exiting Program Mode	24
Programming Guide	25

Basic Programming	.29
Year, Month, and Date	.29
Hours and Minutes	.30
Day Change Time	.31
Daylight Savings Time	.32
Hours Display and Imprint	.35
Index No. Imprint	.37
Signal Duration	.37
Weekly Programming	.39
Creating a Weekly Program	.39
Obtaining a Printout of Programmed Data	.42
Editing Weekly Programs	.43
Adding Additional Weekly Programs	.43
Deleting a Weekly Program	.44
Chapter 5: Maintenance	.45
Service	.45
Exterior	.45
Fuse Replacement	.45
Ribbon Replacement	.46
Chapter 6: Troubleshooting	.49
Introduction	.49
General Problems	.49
Signal 1	.49
Foreign Object or Material	.50
Programming	.50
Key Failure	.50
Audible Beeps	.50
Error Messages	.51
Err 0 thru Err 5	.51
Err 6 thru Err 9	.53
Display Related Problems	.55
Low Battery	.55
Power Failure	.55
Inaccurate Clock	.55
LED's Not Functioning	.55
Hour Change	.56
Slave Master	.56

Card Feed Problems	.56
Card Refused	.56
Card Cannot Enter or Card Blocked	.57
Card Refused, Date and Time in Display	.57
Imprint Problems	.58
Overprint	.58
Imprint Position Wrong	.58
Wrong Color Printed	.59
Weak or Light Printing	.59
Diagnostics	.61
LED Test	.60
Mode and Keys Test	.61
LCD Test	.62
Eprom Test	.62
Buzzer Test	.63
Signal 1 Test	.64
Color Change Test	.64
Model ID	.65
Appendix	.67
Weekly Programming Chart	.67

Specifications

Power Requirements:	120 VAC \pm 10%, 50/60 Hz
Power Consumption:	6W Idle, 60W maximum
Ambient Conditions:	Temperature: -10°C to 45°C (14°F to 113°F) Humidity: 10% to 90% (non condensing)
Dimensions:	313 mm (6.9") High x 258 mm (5.9") Wide x 155 mm (6.0") Deep
Weight:	4.38 kg (9.66 lbs.)
Power Reserve:	The built-in battery, when fully charged, will maintain normal operations for 72 hours or 300 punches.
Environment:	Indoor use only Dust free Not in direct sunlight
Time Card:	Electronically configured for 86 mm (3.375") wide "Clipper" type, and set for a card thickness of 0.32 mm (0.0126"). Unit can be mechanically adjusted to accept card widths of 66 mm to 107 mm (2.6004" to 4.2158") and card thickness of 0.2 mm to 0.5 mm (0.0079" to 0.0197").



289J
TIME RECORDER

Chapter 1: Introduction

External View

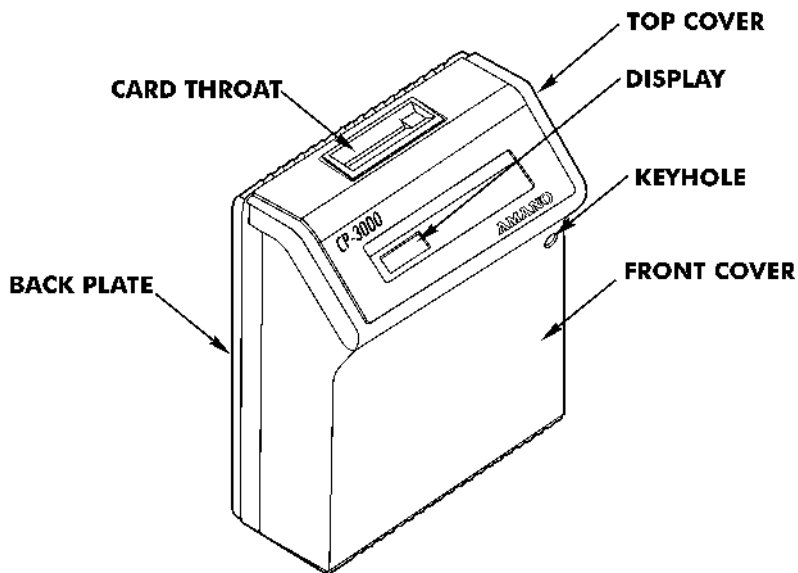

Other Components

- Key
- This Manual

Features

There are three versions of the CP-3000 available. The model numbers and features are listed below.

Features	A050	A051	A056
Single Color Printing	X		
Two Color Printing		X	X
Signal Device		X	X
Full Power Reserve	X	X	X
Index No. Imprint			X

Front Panel Description

The front panel displays the date, time, day of the week and is used for programming. It is accessed by removing the top cover. (See the next page.)

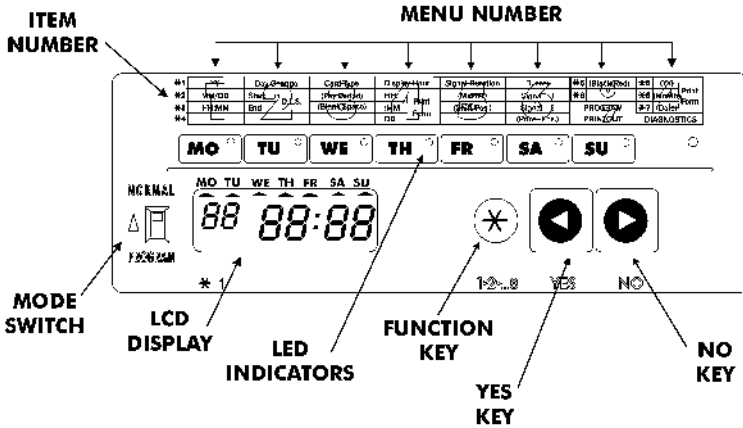

Component	Name	Normal Mode	Program Mode
	LED Indicator	Day of the week	Current menu in display
	Mode Switch	Normal operation	Enter Program Mode, Ribbon replacement
	Function Key	No function	Move to the next menu
	Yes Key	No function	Accept data in the display, and move to the next item in the current menu or next menu.
	No Key	No function	Edit data in the display. Pressing this key will increment the displayed value by one. Holding the key down for more than three seconds will increment the displayed value by ten.

Note: ESD (Electrostatic Discharge) precautions should be adhered to before touching the **Mode Switch**.

Chapter 2: Getting Started

Top Cover

The top cover must be removed to configure, install, and program the CP-3000. To remove the top cover, insert the key in the key hole and turn it clockwise. The top cover should “pop” open. Pivot the top cover upwards and lift to remove.

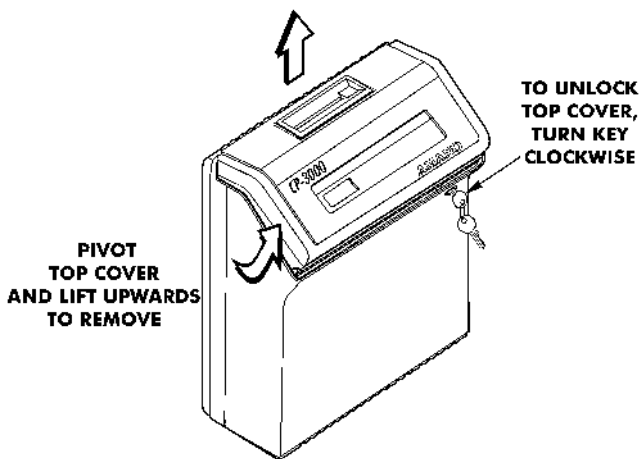

To re-install the top cover, set and align it with the grooves on the housing, then press into place until it clicks.

Front Cover

Removal

The front cover must be removed to connect the Full Power Reserve Battery and connect the external signal line (Model A051 and A056 only) to your CP-3000. To do so, perform the following:

1. Disconnect the power cord from the power source if applicable.
2. Remove the top cover.
3. Lay the unit face up on a flat surface.
4. Facing the front of the unit, remove the two Phillips head screws in the upper corners of the housing.

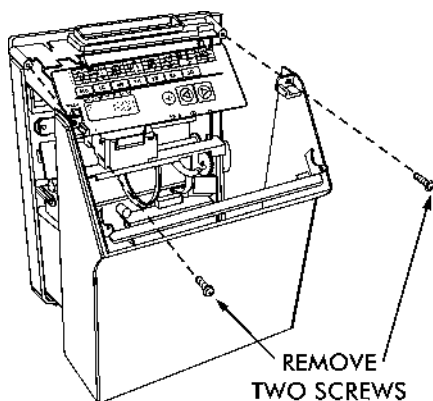

5. Press both of your hands flat against the sides of the front cover.
6. Pivot the front cover towards you and remove. Set face up on a flat surface.

Installation

1. With the front cover on a flat surface and facing up, press both of your hands flat against the sides.
2. Facing the bottom of the unit, set and align the tabs on the bottom of the front cover with the grooves on the housing.
3. Pivot the front cover towards the housing, push it down in place, then secure it with the two Phillips head screws.
4. Re-install the top cover. If necessary, reconnect the power cord to the power source.

Placement/Location

When choosing a mounting location for your CP-3000, you should consider the following:

- the mounting surface and hardware required is capable of supporting the unit's weight, 4.38 kg (9.66 lbs.)
- the area must be within the specified operating temperature range.
- close proximity to a power source or wall outlet
- the area can accommodate signal and/or power conduits
- the following conditions do not exist:



Desktop Installation

Place the time recorder on a level surface. The recommended height of the surface should be 75 cm (29½") from the floor.

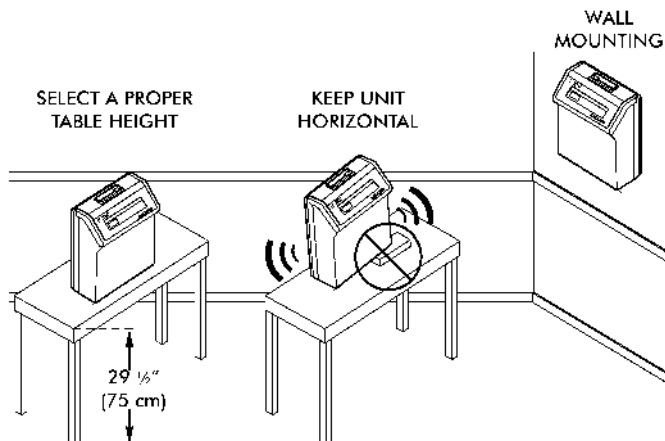

Wall Mounting

1. Disconnect the power cord from the power source.
2. Unlock and remove the top cover.
3. Remove the two screws on the top and slide the back plate downward to remove it. Set the CP-3000 face up on a flat surface.
4. Using a punch, knock out the center material from the teardrop mounting hole on the back plate.
5. Using the back plate as a template, approximate the final location of the clock, and mark the location of the teardrop mounting hole on the wall.
6. Hang the back plate on a screw or anchor from the teardrop mounting hole.
7. Level the back plate and mark the location of the bottom two mounting holes.
8. Secure the back plate to the wall by inserting screws through the bottom two mounting holes.

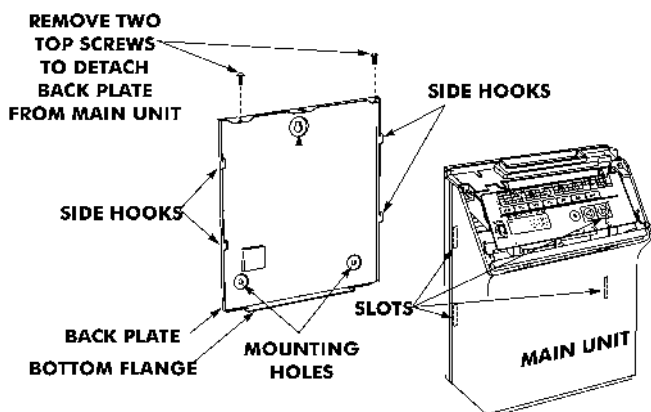

9. Holding the sides of the cover, lift the CP-3000, bottom forward, to the back plate.
10. Align the tabs on the bottom of the CP-3000 housing with the grooves in the bottom flange of the back plate. Hold the CP-3000 in place so that the tabs are even with the bottom flange. Do not rest the unit on the flange.
11. Carefully pivot the CP-3000 away from you onto the back plate until its side hooks fit in the slots on the back of the unit. The upper flange of the back plate should be aligned with the slot in the top of housing.

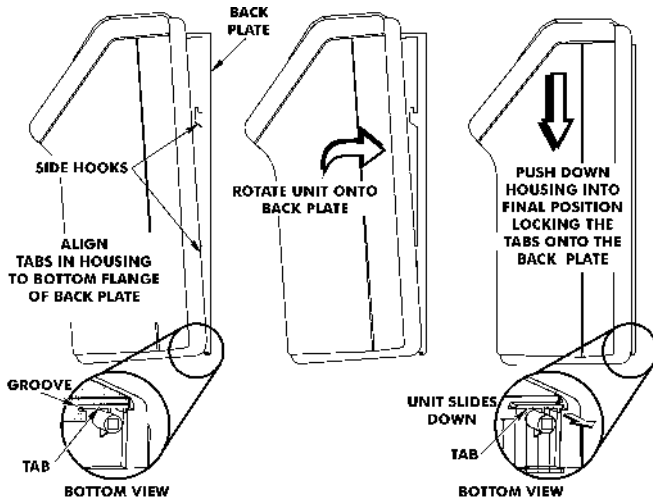

12. Install the two screws that secure the back plate to the unit. Make sure you re-install the ground wire.
13. If you need to connect external signal wiring, or connect the battery, do not replace the top cover or reconnect the power cord at this time.

External Signal Connections

The model A051 and A056 versions of the CP-3000 are equipped with a single external signal relay circuit that enables you to activate an audible device such as a bell or buzzer. The relay contacts of the circuit are Normally Open and should not exceed Class 2 Circuit requirements (30 VAC RMS at 3A or 30 VDC at 3A). It is recommended that a Surge Absorber (Amano P/N ESA-100010) be connected as shown to eliminate and prevent power line noise or electromagnetic interference that might enter the CP-3000 via the relay circuit. The duration (in seconds) that the relay contacts will be activated or closed is set in the **Signal Duration** menu item, and the time of the day and day of the week that this will occur on is set in the **Weekly Programming** menu.

The wiring schematic for the external signal relay circuit is as follows:

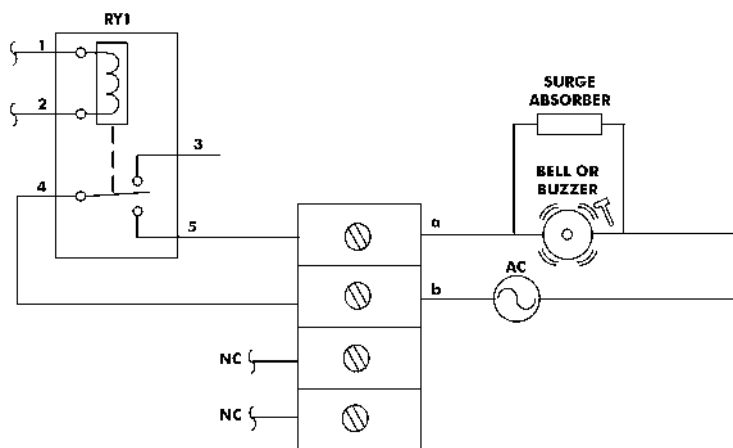

Note: This procedure must be performed with power to both the external device and the CP-3000 disconnected.

To connect a device to the relay signal circuit, perform the following:

1. Make sure that power to both the external device and the CP-3000 are disconnected.
2. Following the manufacturer's guidelines for the external device, connect the signal wires to it and run them to the mounting location of the CP-3000. Make sure the wires are properly labeled.
3. Strip approximately 6.35 mm (.250") of insulation off the ends of the wires that will be connected to the CP-3000.
4. Remove the top cover from the CP-3000.
5. Remove the front cover.

6. With the unit flat and face up, locate terminal block **CN7A/CN7B**, and its corresponding knockout on the bottom of the housing.
7. Using a punch or similar object, remove the knockout for connector **CN7A/CN7B**.
8. Using a screwdriver, loosen the screws on the **CN7A** side of the connector block.
9. Observing polarity, insert one wire into the CP-3000 through the knockout hole and connect it to the proper terminal position of **CN7A**. Using a screwdriver, secure the wire in place. Insert the other wire into the unit and secure in place. Make sure that only the stripped wire is clamped, and not the insulation.

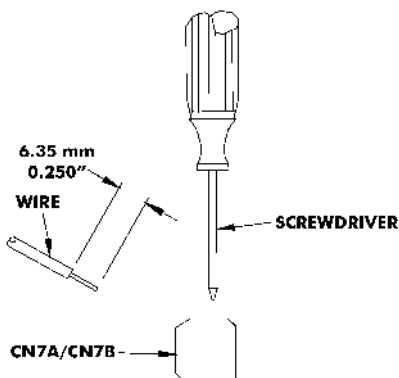

10. Check the connections by tugging on each wire. If they appear loose, repeat the previous step.
11. Clamp the signal wires as shown using a cable clamp appropriate to your cable thickness.

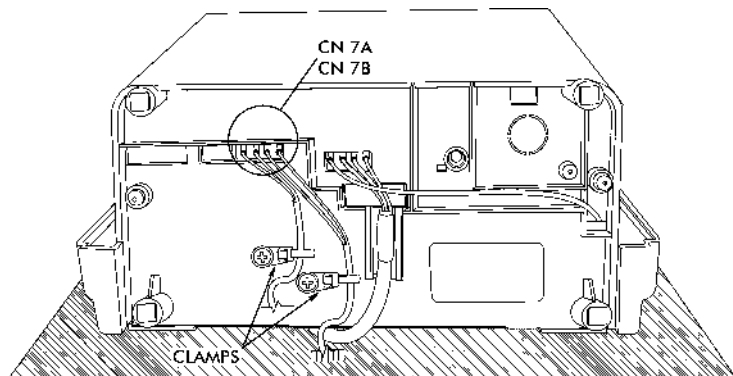

Connecting the Battery

The CP-3000 is equipped with a Full Power Reserve Battery that will maintain normal operations for 72 hours or 300 punches, in the event of an AC power failure. This battery is disconnected at the factory to prevent damage during shipping and must be connected for the CP-3000 to operate.

Note: This procedure must be performed with the power cord disconnected from the power source.

To connect the Full Power Reserve Battery perform the following:

1. Remove the top cover.
2. Remove the front cover.
3. Locate the battery cable. This is a pair of red and black wires protruding from the chassis.

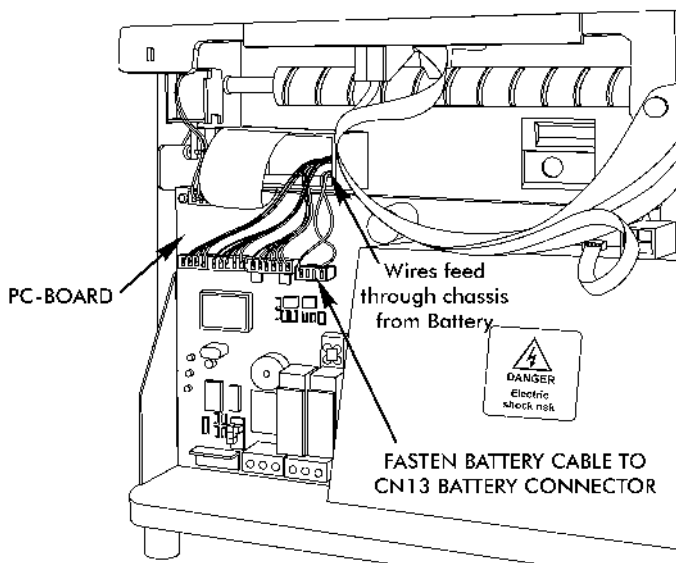

UNIT WITH FRONT COVER REMOVED

4. Connect the battery cable to **CN13** on the PC Board. If the battery is properly connected, the following will occur:
 - the LCD will display the default time in the “As Shipped” (12 hour) format:

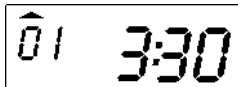

- an LED indicator will blink
 - the ribbon carriage will cycle
5. Replace the front cover.
 6. Replace the top cover.

Note: The “As Shipped” time display format setting is configured at the factory. If the CP-3000 should lose its configuration, the time will be displayed in the default (24 hour) time format when the battery is connected.

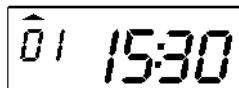

Please refer to the **Basic Programming** section of **Chapter 4** to set the year, time, date, and the hours display format.

Note: The battery is fully charged prior to shipping, however, to insure premium performance it is recommended that the battery be fully recharged prior to use (approximately 24 hours).

Note: To avoid damaging the battery, or draining it to an unrecoverable level, keep the machine plugged into an AC power source during normal operation. The power reserve battery is intended to be used for limited power outages, not as a power source during normal operations.

Initialization and Reset

Initialization

Prior to first use, the CP-3000 must be initialized. Initialization resets the time and date to their default settings, but does not affect their “As Shipped” format.

Note: This procedure must be performed with the power cord disconnected from the power source.

With the power cord disconnected, insert a small screwdriver into the **Reset Hole**, on the bottom of the unit, and press the **Reset** button.

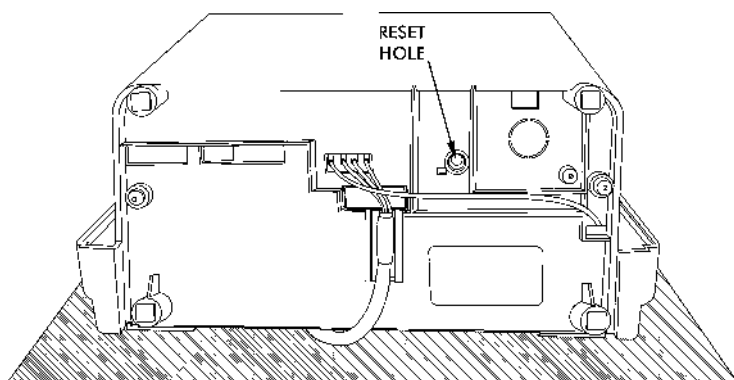

The CP-3000 should be re-initialized whenever the battery has been disconnected or severely drained of power.

Note: Initialization or pressing the **Reset** button does not mean that all program data is reset to defaults. Only the time and date are reset to defaults. The CP-3000 is reset to defaults by performing a Reset (All Clear).

Reset (All Clear)

This function is provided to clear all programmed data (**Weekly Programs**, imprint formatting, etc.) from the CP-3000. When used, all programmed data will be erased (including the “As Shipped” formats) and the unit will be returned to its default settings. You should only reset your CP-3000 when prescribed to in the **Troubleshooting** section of this manual.

Note: ESD (Electrostatic Discharge) precautions should be adhered to before touching the **Mode Switch**.

To Reset (Clear All) your CP-3000, perform the following:

1. Set the **Mode Switch** to **PROGRAM**.
2. Insert a small screwdriver into the **Reset Hole**, on the bottom of the unit, and press and hold the the **Reset** button.
3. While holding the **Reset** button, press and hold the **YES** and **FUNCTION** buttons.
4. Release the **Reset** button. Five beeps will sound
5. Release the **YES** and **FUNCTION** buttons and and set the **Mode Switch** to **NORMAL**.

Power Connection

Power connections are made by plugging the power cord into a suitable, grounded outlet.

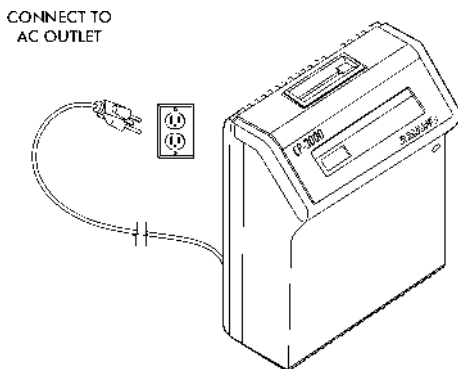

When the AC power is properly connected, the LED will cease to flash and the LCD display will show normal time indication in the “As Shipped” (12 hour) format:



Note: The “As Shipped” time display format setting is configured at the factory. If the CP-3000 should lose its configuration, the time will be displayed in the default (24 hour) time format when the power is connected.



Please refer to the **Basic Programming** section of **Chapter 4** to set the year, time, date, and the hours display format.

Note: The battery is fully charged prior to shipping, however, to insure premium performance it is recommended that the battery be fully recharged prior to use (approximately 24 hours).

Note: To avoid damaging the battery, or draining it to an unrecoverable level, keep the machine plugged into an AC power source during normal operation. The power reserve battery is intended to be used for limited power outages, and not as a power source during normal operations.

Card Dimensions

The CP-3000 is factory set for use with an 86 mm (3.375") wide and 0.32 mm (0.0126") thick standard "Clipper" type time card. The recommended column dimensions are as follows:

Card Dimensions

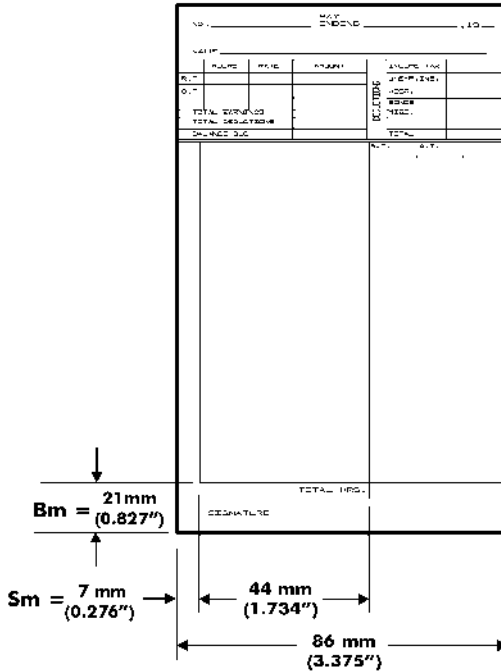

where:

Bm = Bottom Margin, 21 mm (0.827") from bottom of time card

Sm = Side Margin, 7 mm (0.276") from left edge of time card

Imprint Length = 44 mm (1.734")

The CP-3000 allows you the flexibility to modify the time card dimensions if your application requires it. The **Bottom** and **Side Margins** of the imprint are adjusted in the **Program Mode**. The time card width and thickness are mechanical adjustments to the card throat.

Card Color

The CP-3000 can be used with most of the colored time cards available. However, when selecting a time card, you should make sure that the background color of the card does not interfere with the time card sensors' ability to read the contrast between the card and the **Column Position Block** in the imprint (see page 15). In addition, the surface of the time card should be smooth, and clean of any oil, dirt, or dust. A rough or soiled card surface will also impede the time card sensors' ability to read the **Column Position Block** in the imprint.

Time Card Settings

The **Time Card Settings** menu in the **Program Mode** is used to verify that the **Card Type Setting** is correct and to adjust the **Bottom (Bm)** and **Side (Sm) Margins** of the imprint. When adjusting these margins, the length and location of the imprint should be taken into consideration. Since the CP-3000 uses the **Column Position Block** on the imprint to record column position, the imprint can not be aligned with any corresponding lines or artwork in the card. If this occurs, the card will be ejected and a "beep" will sound.

Card Type Setting

The only allowable **Card Type Setting** for the CP-3000 is "18". This setting corresponds to an 86 mm (3.375") wide "Clipper" type card. This card type is recommended, but others can be used. The card width can be adjusted mechanically by setting the width of the card throat. To verify the **Card Type Setting**, perform the following:

1. Remove the top cover.

Note: ESD (Electrostatic Discharge) precautions should be adhered to before touching the **Mode Switch**.

2. Enter the **Program Mode** by setting the **Mode Switch** to **PROGRAM**.



3. Press the **FUNCTION** key until the **Time Card Settings** menu item appears in the display.



4. Press the **NO** key to select the **Card Type Setting Password** of "5".

5. When the correct value appears in the display, press the **YES** key. A password confirmation display will appear. If the value in the display is correct, press the **YES** key.
6. The **Card Type Setting Password** menu item will appear. It should be set to "18". If it is not, press the **NO** key until "18" appears in the display, then press the **YES** key twice.
7. When saved, the next menu item, **Day Change Time**, will appear in the display.
8. Exit the **Program Mode** and insert a time card into the card throat to test.

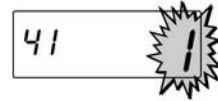

Side Margin (Sm) Adjustment

1. If you have not already done so, enter the **Program Mode** and press the **FUNCTION** key until the **Time Card** menu item appears in the display.
2. Press the **NO** key to select the **Side Margin Adjustment Password** of "8".
3. When the correct value appears in the display, press the **YES** key. A password confirmation display will appear. If the value in the display is correct, press the **YES** button.
4. The **Side Margin** menu item will appear. Press the **NO** key to change the flashing value in the display. Acceptable values are from 01 to 31 in increments of 0.25 mm (0.01"). When the correct value appears, press the **YES** key.
5. Exit the **Program Mode** and insert a time card into the card throat to test.



Note: This feature is only for **small** variations.

Bottom Margin (Bm) Adjustment

1. If you have not already done so, enter the **Program Mode** and press the **FUNCTION** key until the **Time Card** menu item appears in the display.
2. Press the **NO** key to select the **Bottom Margin Adjustment Password** of "9".
3. When the correct value appears in the display, press the **YES** key. A password confirmation display will appear. If the value in the display is correct, press the **YES** key.
4. The **Bottom Margin** menu item will appear. Press the **NO** key to change the flashing value in the display. Acceptable values are from 01 to 31 in increments of 0.25 mm (0.01"). When the correct value appears, press the **YES** key.
5. Exit the **Program Mode** and insert a time card into the card throat to test.



Note: This feature is only for **small** variations.

Card Thickness Adjustment

The CP-3000 is factory set for a time card thickness of 0.32 mm (0.0126"). It can be adjusted for time cards with a thickness of 0.2 mm to 0.5 mm (0.0079" to 0.0197").

To set the card thickness, perform the following:

1. Disconnect the power cord from the power source.
2. Remove the top cover.
3. Set the **Mode Switch** to **PROGRAM**.
4. Remove the front case.
5. Disconnect the battery.
6. Card thickness is adjusted by turning the white dials (on both sides of the printer platen) to the thickness of the card. Clockwise rotation of the dials narrows the gap and counterclockwise rotation widens the gap. One click of each dial is 0.06 mm (.0024")

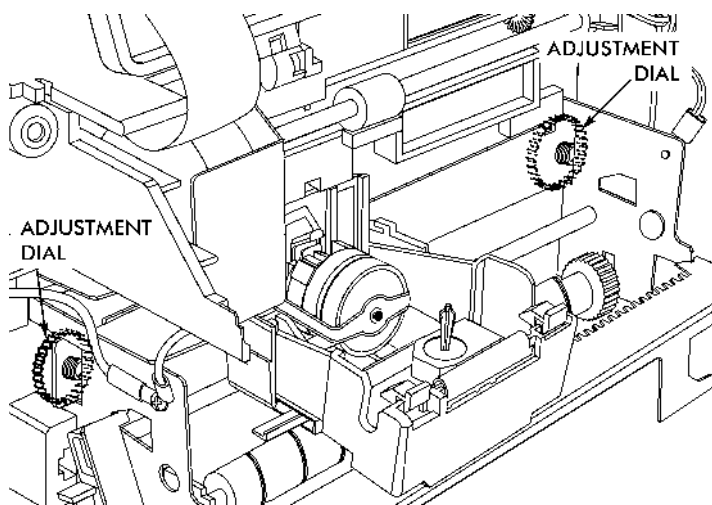

7. Reconnect the battery.
8. Install the front cover.
9. Reconnect the power cord to the power source.
10. Program the correct time and date.
11. Set the **Mode Switch** to **NORMAL** and install the top cover.

Card Width Adjustment

The card throat width is pre-set for an 86 mm (3.375") wide card. The width can be adjusted from 66 mm to 107 mm (2.6004 to 4.2158").

1. Disconnect the power cord from the power source.
2. Remove the top cover.
3. Set the **Mode Switch** to program.
4. Remove the front case.
5. Disconnect the battery.
6. Loosen the upper card width adjustment screw, insert the card into the card throat and slide the guide to adjust the width allowing 0.5 mm (0.0197") between the card and the guide. Tighten the screw.

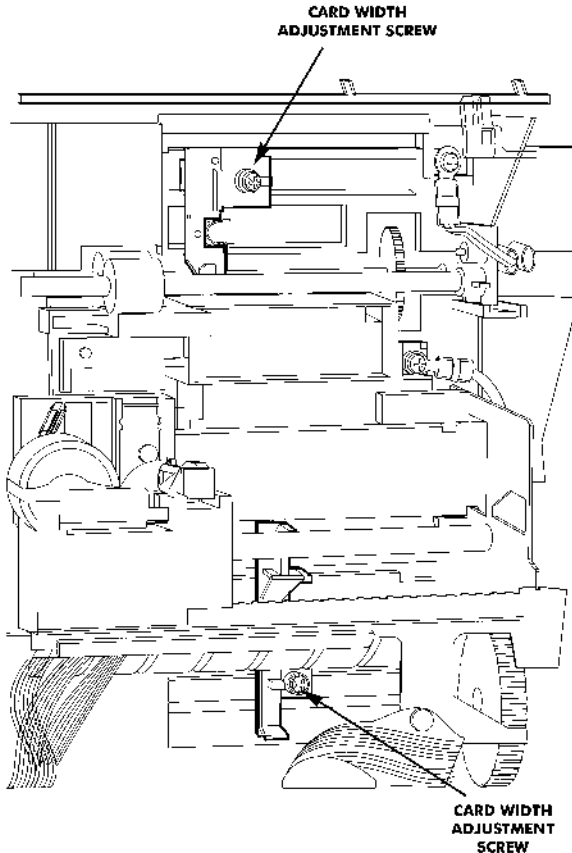

7. Loosen the lower card width adjustment screw, insert the card into the card throat and slide the guide to adjust the width allowing 0.5 mm (0.0197") between the card and the guide. Tighten the screw.
8. Reconnect the battery.
9. Install the front cover.
10. Reconnect the power cord to the power source.
11. Program the correct time and date.
12. Set the **Mode Switch** to **NORMAL** and install the top cover.

Chapter 4: Programming

Introduction

The CP-3000 must be programmed before use. There are two types of programming: **Basic** and **Weekly**.

Basic Programming is used to program basic clock functions such as time, date, time display, Daylight Saving Time (DST) adjustment, and card imprint.

Weekly Programming consists of activating specific features of the CP-3000 such as the built-in buzzer, relay signal contacts, ribbon color (two color only) at predetermined times of the day and on specific days of the week.

General Programming Guidelines

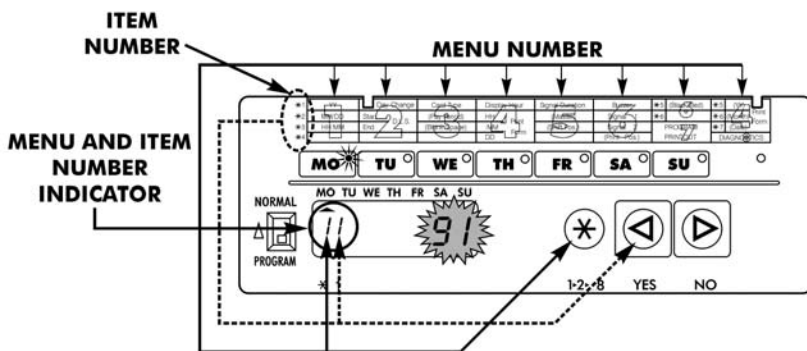

Entering Program Mode

Note: ESD precautions should be adhered to before touching the **Mode Switch**.

To enter the **Program Mode**, remove the top cover and set the **Mode Switch** to **PROGRAM**. The first program menu item will appear in the display and the first LED indicator will illuminate.

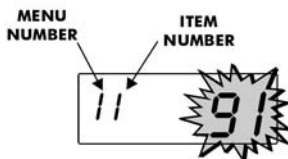

Entering and Saving Values

Values are changed in each programming menu item by pressing the **NO** key. Holding down the **NO** key for more than three seconds will increment the value more rapidly. For example, year values (00 to 99) will be incremented by a value of ten when the **NO** key is pressed for more than three seconds.

To save values entered, press the **YES** key. Some menus and items require that the entire sequence be cycled through before saving the values entered.



Scrolling Through the Program Mode





While in the **Program Mode**, press the **FUNCTION** key to advance to the next menu position. An LED indicator will light for each menu position. Continue pressing the **FUNCTION** key and the cursor will eventually return to the first program item.

Exiting Program Mode

To exit the **Program Mode** at any time, slide the **Mode Switch** to the **NORMAL** position.

Programming Guide











The following is a reference guide for programming the A050 and A051 versions of the CP-3000:

Indicator	Menu/Item	Description	Display	Accepted Values
MO 	11	Year	11 91	00 to 99
	12	Month and Date	12 0101	Month: 01XX to 12XX Date: XX01 to XX31
	13	Hour and Minutes	13 1530	Hours: 00XX to 23XX Minutes: XX00 to XX59
TU 	21	Day Change Time	21 0000	Hours: 00XX Minutes: XX00
	22	DST Begin	22 0000	Weekly: 0001 to 0052 Month: 01XX to 12XX Date: XX01 to XX31
	23	DST End	23 0000	Weekly: 0001 to 0052 Month: XX01 to XX12 Date: XX01 to XX31
WE 	31	Time Card Setting	31 0	5: Card Type Setting 8: Side Margin Adjustment 9: Bottom Margin Adjustment
	35	Card Type Setting	35 18	18
	38	Side Margin Adjustment	38 16	01 to 31
	39	Bottom Margin Adjustment	39 16	01 to 31
TH 	41	Hour Display	41 1	1: 24 hour format ¹ 2: 12 hour format ²
	42	Hour Imprint	42 1	1: 24 hour format ¹ 2: 12 hour format ²
	43	Fraction of Hours Imprint	43 1	1: 60th ^{1,2} 2: 10th 3: 100 A ¹ (36 sec. = 0.01h) 4: 100 B (3 sec. = 0.05h) 0: None 1: Date (01 to 31) ² 2: Day of Week (D1 to D7) ¹
	44	Day Imprint	44 2	3: Day of Week (English) 4: Day of Week (Spanish) 5: Day of Week (French) 6: Day of Week (German) 7: Day of Week (Dutch) 8: Day of Week (Italian)

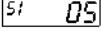
Notes:

1. Default Value
2. As Shipped

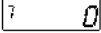
(Chart continued on next page)

Indicator	Menu/Item	Description	Display	Accepted Values
 (Cont'd)	45	Year Imprint		0: Off 1: On ^{1, 2}
	46	Month Imprint		0: None 1: Month (1 to 12) 2: Month (I to XII) 3: Month (English) ^{1, 2} 4: Month (Spanish) 5: Month (French) 6: Month (German) 7: Month (Dutch) 8: Month (Italian)
	47	Additional Date Imprint		0: Day Imprint Only 1: Additional 01 to 31 ^{1, 2}
	51	Signal Duration		01 to 12 Seconds
	52	Master Clock		0: No Master/Slave
	01 to 80	Weekly Program		01 to 80 Programs
	7	Program Printout		0: Off 1: Program Printout
	8	Diagnostics		01: LED Test 02: Mode and Keys Test 03: LCD Test 04: Eprom Test 05: Buzzer Test 06: Signal 1 Test 07: Not Used 08: Color Change Test 09: Not Used 10: Model ID 11: Not Used





Notes:

1. Default Value

2. As Shipped

Note: The “As Shipped” imprint settings are configured at the factory. If the CP-3000 should lose its configuration, it will revert to the default imprint settings.

The following is a reference guide for programming the Model A056 version of the CP-3000:





Indicator	Menu/Item	Description	Display	Accepted Values
MO 	11	Year	<u>11</u> 91	00 to 99
	12	Month and Date	<u>12</u> 0101	Month: 01XX to 12XX Date: XX01 to XX31
	13	Hour and Minutes	<u>13</u> 1530	Hours: 00XX to 23XX Minutes: XX00 to XX59
TU 	21	Day Change Time	<u>21</u> 0000	Hours: 00XX Minutes: XX00
	22	DST Begin	<u>22</u> 0000	Weekly: 0001 to 0052 Month: 01XX to 12XX Date: XX01 to XX31
	23	DST End	<u>23</u> 0000	Weekly: 0001 to 0052 Month: XX01 to XX12 Date: XX01 to XX31
WE 	31	Time Card Setting	<u>31</u> 0	5: Card Type Setting 8: Side Margin Adjustment 9: Bottom Margin Adjustment
	35	Card Type Setting	<u>35</u> 18	18
	38	Side Margin Adjustment	<u>38</u> 16	01 to 31
	39	Bottom Margin Adjustment	<u>39</u> 16	01 to 31
TH 	41	Hour Display	<u>41</u> 1	1: 24 hour format ¹ 2: 12 hour format ²
	42	Hour Imprint	<u>42</u> 1	1: 24 hour format ¹ 2: 12 hour format ²
	43	Fraction of Hours Imprint	<u>43</u> 1	1: 60th ^{1,2} 2: 10th 3: 100 A ¹ (36 sec. = 0.01h) 4: 100 B (3 sec. = 0.05h) 0: None 1: Date (01 to 31) 2: Day of Week (D1 to D7) 3: Day of Week (English) ^{1,2} 4: Day of Week (Spanish) 5: Day of Week (French) 6: Day of Week (German) 7: Day of Week (Dutch) 8: Day of Week (Italian) 9: Print Index No. (Item 48)
	44	Day Imprint	<u>44</u> 3	

Notes:

1. Default Value
2. As Shipped

ATP-007440

(Chart continued on next page)

Indicator	Menu/Item	Description	Display	Accepted Values
 (Cont'd)	45	Year Imprint	45 1	0: Off 1: On ^{1, 2}
	46	Month Imprint	46 3	0: None 1: Month (1 to 12) 2: Month (I to XII) 3: Month (English) ^{1, 2} 4: Month (Spanish) 5: Month (French) 6: Month (German) 7: Month (Dutch) 8: Month (Italian)
	47	Additional Date Imprint	47 1	0: Day Imprint Only 1: Additional 01 to 31 ^{1, 2}
	48	Index No. Imprint	48 0	0 to 99 Machine Index Number
	51	Signal Duration	51 05	01 to 12 Seconds
	52	Master Clock	52 0	0: No Master/Slave
	01 to 80	Weekly Program	01	01 to 80 programs
	7	Program Printout	7 0	0: Off 1: Program printout
	8	Diagnostics	8 01	01: LED Test 02: Mode and Keys Test 03: LCD Test 04: Eeprom Test 05: Buzzer Test 06: Signal 1 Test 07: Not Used 08: Color Change Test 09: Not Used 10: Model ID 11: Not Used

Notes

1. Default Value
2. As Shipped

Note: The “As Shipped” imprint settings are configured at the factory. If the CP-3000 should lose its configuration, it will revert to the default imprint settings.

Basic Programming

Year, Month, and Date

Note: To set the year, month, and date, you must cycle through the following sequence of displays and save the data entered.

The data entered will not be saved if you exit the **Program Mode** or press the **FUNCTION** key before saving.

1. Set the **Mode Switch** to the **PROGRAM** position. The **Year** menu item will automatically appear in the display.
2. Press the **NO** key until the correct two digit year (00 thru 99) is flashing in the display. Holding down the **NO** key for more than three seconds will increment the number in the display by ten.
3. When the correct year appears, press the **YES** key. The display will automatically move to the **Month and Date** menu item. The first pair of digits (month) will flash in the display.
4. Press the **NO** key until the correct month number (01 thru 12) appears in the display, then press the **YES** key.
5. The next set of digits, the **Date of the Month** will flash in the display.
6. Press the **NO** key until the correct date of the month (01 thru 31) appears in the display, then press the **YES** key.
7. The year, month, and date entered will flash in the display. To edit these settings, press the **NO** key. This will return you to the display described in step 1. To save these settings, press the **YES** key. When the year, month and date are saved, the next menu item, **Hours and Minutes** will appear in the display.



Note: After saving the date, the LED indicator on the front panel will automatically adjust to the correct day of the week when switched to **NORMAL**.

Hours and Minutes

Note: To set the hours and minutes, you must cycle through the following sequence of displays and save the data entered. The data entered will not be saved if you exit the **Program Mode** or press the **FUNCTION** key before saving.

Note: All time programming is done in 24 hour time format, even if the time is displayed in 12 hour time format. The default time format for the display in **NORMAL** mode is also 24 hour format. If you wish to change the time format for the display, you must do so in the **Hours Display** menu item.

1. Set the **Mode Switch** to the **PROGRAM** position, if you have not already done so. The **Year** menu item will automatically appear in the display.



2. If applicable, press the **YES** key until the **Hours and Minutes** menu item appears in the display with the first pair of digits (hour) flashing.



3. Press the **NO** key until the correct hour (in 24 hour format, 00 thru 23) is flashing in the display. Holding down the **NO** key for more than three seconds will increment the number in the display by ten.



4. When the correct hour appears, press the **YES** key. The second pair of digits, minutes, will begin to flash.



5. Press the **NO** key until the correct minutes (00 thru 59) appear in the display. Holding down the **NO** key for more than three seconds will increment the number in the display by ten.



6. When the correct minutes appears in the display, press the **YES** key.

7. The hour and minutes entered will flash in the display. To edit these settings, press the **NO** key. This will return you to the display described in step 2. To save these settings, press the **YES** key. When saved, the next menu item, **Day Change Time**, will appear in the display.



Day Change Time

For proper operation of the CP-3000, the **Day Change Time** must be set to "00:00". To do so, perform the following:

Note: To verify the **Day Change Time** you must cycle through the sequence of displays and save the data displayed. The data entered will not be saved if you exit the **Program Mode** or press the **FUNCTION** key before saving.

1. If you have not already done so, enter the **Program Mode** and press the **FUNCTION** key until the **Day Change Time** menu item appears with the first pair of digits (hour) flashing in the display.
2. Verify that "00" is flashing in the display and press the **YES** key. The second pair of digits (minutes) will begin to flash.
3. Verify that "00" is flashing in the display and press the **YES** key.
4. The hour and minutes entered will flash in the display. Verify that they are both set to "00" and press the **YES** key. When saved, the next menu item, **DST Begin Date** (increment by one hour) will appear in the display with the first pair of digits (month) flashing.



Daylight Savings Time

The Daylight Saving Time (DST) hour adjustment can be either programmed to occur automatically or adjusted manually.

Automatic Adjustment

To program for DST, you must specify the day that the DST period will begin or end, by date or week number. If a date is specified, the time change will occur at 2:00 am on the begin and end dates. If a week is specified, the time change will occur at 2:00 am on the Sunday of the programmed week. You must set the **DST Begin Date** (increment by one hour) and **End Date** (decrement by one hour) once each year. If no **DST Begin Date** is specified, the automatic DST adjustment will be disabled.

Note: To set the **DST Begin Date** and **End Date** you must cycle through the sequence of displays of each item and save the data entered. The data entered will not be saved if you exit the **Program Mode** or press the **FUNCTION** key before saving.

By Week Number

1. If you have not already done so, enter the **Program Mode** and press the **FUNCTION** key until the **Day Change Time** menu item appears in the display.
2. Press the **YES** key three times until the **DST Begin Date** menu item appears with the first pair of digits (month) flashing in the display. Verify that these digits are "00" and press the **YES** key. The second pair of digits (week number) will flash in the display.
3. Press the **NO** key until the correct week number of the year (01 thru 52) appears in the display. Holding down the **NO** key for more than three seconds will increment the number in the display by ten.



4. When the desired value is displayed, press the **YES** key. The week number will flash in the display. To edit these settings, press the **NO** key. This will return you to the display described in step 2. To save these settings, press the **YES** key. When saved, the next menu item, **DST End Date** will appear in the display with the first pair of digits (month) flashing in the display.
5. Press the **NO** key until the correct week number of the year (01 thru 52) appears in the display. Holding down the **NO** key for more than three seconds will increment the number in the display by ten.
6. Press the **YES** key. The value entered will flash in the display. To edit these settings, press the **NO** key. This will return you to the display described in step 4. To save these settings, press the **YES** key. When saved, the display will move to the **Time Card Settings** menu.
7. Exit the **Program Mode** by setting the **Mode Switch** to **NORMAL**.



By Month and Day

1. If you have not already done so, enter the **Program Mode** and press the **FUNCTION** key until the **Day Change Time** menu item appears in the display.
2. Press the **YES** key three times until the **DST Begin Date** menu item appears with the first pair of digits (month) flashing in the display.
3. Press the **NO** key until the correct month number (01 thru 12) appears in the display, and then press the **YES** key. Holding down the **NO** key for more than three seconds will increment the number in the display by ten. When saved, the second pair of digits (date of the month) will flash in the display.



4. Press the **NO** key until the date of the month (01 thru 31) appears in the display. Holding down the **NO** key for more than three seconds for both options will increment the number in the display by ten.



5. When the desired value is displayed, press the **YES** key. The date will flash in the display. To edit these settings, press the **NO** key. This will return you to the display described in step 2. To save these settings, press the **YES** key. When saved, the next menu item, **DST End Date** will appear in the display with the first pair of digits (month) flashing in the display.



6. Press the **NO** key until the correct month (01 thru 12) appears in the display. Holding down the **NO** key for more than three seconds will increment the number in the display by ten. To edit these settings, press the **NO** key. To save these settings, press the **YES** key. When saved, the the second pair of digits (date) will flash in the display.



7. Press the **NO** key until the correct date (01 thru 31) appears in the display. Holding down the **NO** key for more than three seconds will increment the number in the display by ten.



8. Press the **YES** key. The value entered will flash in the display. To edit these settings, press the **NO** key. This will return you to the display described in step 2. To save these settings, press the **YES** key. When saved, the display will move to the **Time Card Settings** menu.



9. Exit the **Program Mode** by setting the **Mode Switch** to **NORMAL**.

Manual Adjustment

To increment the time displayed by one hour, press and hold down the **YES** key while sliding the **Mode Switch** to **PROGRAM**.

To move the time displayed back by one hour, press and hold down the **NO** key while sliding the **Mode Switch** to **PROGRAM**.

Hours Display and Imprint

This group of menu items is used to set the time format (12 or 24 hour) of the display in **NORMAL** mode and the imprint that will appear on the time card.

1. Enter the **Program Mode** and press the **FUNCTION** key until the **Hours Display** menu item appears in the display.
2. Press the **NO** key to select a value of "1" for 24 hour time format or "2" for 12 hour time format.
3. When the desired value appears, press the **YES** key. The display will automatically move to the **Hour Imprint** menu item.
4. Press the **NO** key to select a value of "1" for 24 hour time format or "2" for 12 hour time format. If "2" is selected, an "A" or "P" will appear before the time in the imprint.
5. When the desired value appears, press the **YES** key. The display will automatically move to the **Fraction of Hours (Minutes) Imprint** menu item.
6. Using the **NO** key, select one of the following:



Accepted Values	Imprint
1	60ths
2	10ths
3	100ths A' (36 sec. = 0.01h)
4	100ths B (3 min. = 0.05h)

7. When the desired value appears, press the **YES** key. The display will automatically move to the **Day Imprint** menu item.



8. Using the **NO** key, select one of the following:

Accepted Values	Imprint
0	None
1	Date (00 thru 31)
2	Day of Week (D1 thru D7)
3	Day of Week (English)
4	Day of Week (Spanish)
5	Day of Week (French)
6	Day of Week (German)
7	Day of Week (Dutch)
8	Day of Week (Italian)
9	Print Index No. (A056 only)

Note: For Model A056 only: The **Day Imprint** must have a value of “9” for the Index No. Imprint to appear on the time card.

9. When the desired value appears, press the **YES** key. The display will automatically move to the **Year Imprint** menu item.



10. Press the **NO** key to select a value of “0” for no year imprint (OFF) or “1” to include the year in the imprint (ON).

11. When the desired value appears, press the **YES** key. The display will automatically move to the **Month Imprint** menu item.



12. Using the **NO** key, select one of the following:

Accepted Values	Imprint
0	None
1	Month (00 thru 12)
2	Month (I thru XII)
3	Month (English)
4	Month (Spanish)
5	Month (French)
6	Month (German)
7	Month (Dutch)
8	Month (Italian)

13. When the desired value appears, press the **YES** key. The display will automatically move to the **Additional Date Imprint** menu item.

14. Press the **NO** key to select a value of “0” to disable this feature or “1” to include an additional date of the month (00 to 31) in the imprint.



15. When the desired value appears, press the **YES** key. When saved, the next menu item, **Signal Duration (Model A051) or Index No. Imprint (Model A056)** will appear in the display.

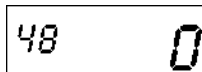

Index No. Imprint (Model A056 only)

This menu item is used to identify individual time clocks on time cards using a Index No. Imprint numbered 00 thru 99.

Note: The **Day Imprint** must have a value of "9" for the Index No. Imprint to appear on the time card.

1. Enter the **Program Mode** and press the **FUNCTION** key until the **Index No. Imprint** menu item appears in the display.
2. Press the **NO** key to select a value of 00 thru 99 that will be used to identify this time clock on a time card.
3. When the desired value appears, press the **YES** key. The display will automatically move to the **Signal Duration** menu item.



Signal Duration

This group of menu items is used to set the duration (in seconds) that the relay contacts of the installed signal device (Models A051 and A056 only) will be closed or the built-in buzzer will sound, and verify that the **Master Clock** function is disabled.

1. Enter the **Program Mode** and press the **FUNCTION** key until the **Signal Duration** menu item appears in the display.
2. Press the **NO** key to select a value of one to twelve seconds that relay contacts of the signal device will be closed.
3. When the desired value appears, press the **YES** key. The display will automatically move to the **Master Clock** menu item.
4. This menu item is used for verification only. The value in the display should be zero. If it is not, press the **NO** key until zero appears in the display, then press the **YES** key.
5. Exit the **Program Mode** by setting the **Mode Switch** to **NORMAL**.

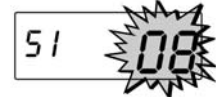

Weekly Programming

This menu allows you to create a weekly schedule that will enable or disable certain features of the CP-3000 at predetermined times of the day and on specific days of the week. This schedule is comprised of two components: Moments and Objects. They are:

Moments	Objects
Days of the Week	Built-in Buzzer
Time of the Day	Signal 1 (Model A051 and A056 Only)
	Signal 2 (Not Used)
	Ribbon Color (Model A051 and A056 Only)

Up to eighty Weekly Programs or schedules can be entered into the CP-3000. Programming charts are provided in the Appendix to help you set up weekly programs. A sample **Weekly Program** is shown below:

Program No.	Moment						Time	Object				
	Days							1. Buzzer	2. Signal 1	3. Signal 2	5. Color	
	1	2	3	4	5	6	7	0: Off 1: On	0: Off 1: On	0: Off	0: No Change 1: Black 2: Red	
01		X		X	X			08:27	0	1	0	1
02		X		X	X			10:12	1	0	0	2

In this example, at 8:27 am, on the second (Tuesday), fourth (Thursday), and fifth (Friday) day of the week, Signal 1 will activate for the duration specified, and the CP-3000 will print in black ink. At 10:12 on the same days, the built in buzzer will sound for the duration specified, and the CP-3000 will print in red ink.

Creating a Weekly Program

Note: To create a program or schedule you must cycle through the sequence of displays of each program number, and save the data entered. The data entered will not be saved if you exit the **Program Mode** or press the **FUNCTION** key before saving.

1. Enter the **Program Mode** and press the **FUNCTION** key until the **Weekly Program** menu item appears in the display. The first program number will appear, with the first cursor or day of the week (Monday) flashing in the display.



2. Press the **NO** key to (deselect) omit days of the week from the schedule or press the **YES** key to (select) include days of the week on the schedule. Days that the schedule will operate on will be shown in the display as cursors.



3. When the days of the week are selected, the display will flash the hour of the selected days that the schedule will be activated.



Note: All time programming is done in 24 hour time format, and cannot be changed to 12 hour format.

4. Press the **NO** key until the hour of the day (00 thru 23) appears in the display, then press the **YES** key. The digits that represent the minutes of the hour will appear and flash in the display.



5. Press the **NO** key until the correct minutes (00 thru 59) appear in the display, then press the **YES** key. This is the time (hours and minutes) that the schedule will be activated on the selected days of the week. The display will move to the **Buzzer**, which is the first object to be turned on or off in the schedule.



Note: The duration (0 to 12 seconds) that the **Buzzer** will be ON for is set in the **Signal Duration** menu item.

6. Press the **NO** key to enter a value of "0" to disable (OFF) or "1" to enable (ON) the **Buzzer**. When the correct value appears in the display, press the **YES** key. The display will move to the next object, **Signal 1**.



Note: The duration (0 to 12 seconds) that the relay contacts of **Signal 1** will be closed for is set in the **Signal Duration** menu item.

7. Press the **NO** key to enter a value of "0" to disable (OFF) or "1" (**For Model A051 and A056 only**) to enable (ON) **Signal 1**. When the correct value appears in the display, press the **YES** key. The display will move to the next object, **Signal 2**.

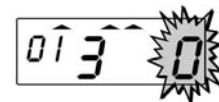

8. This menu item is used for verification only. The value in the display should be zero. If it is not, press the **NO** key until zero appears in the display, then press the **YES** key. The display will move to the **Color Change** item.



Note: For Models A051 and A056 only: If you program a color change, you must program another step or schedule to return the ribbon to its original color.

9. **For Model A051 and A056 only.** Press the **NO** key to enter a value of "0" for no color change, "1" to change to black ink, or "2" to change to red ink.



10. When the desired value is displayed, press the **YES** key. The program number, days of the week, and time of the day that the program will be activated will flash in the display. To edit these settings, press the **NO** key. This will return you to the display described in step 1. To save these settings, press the **YES** key. When saved, the display will move to the next program number.



11. Repeat the previous steps to enter in the next program. As a convenience, the new program will have the same day settings as the previous program. To clear the days of the week, press the **NO** key.



12. Exit the **Program Mode** by setting the **Mode Switch** to **NORMAL**.

Obtaining a Printout of Programmed Data

1. If you have not already done so, enter the **Program Mode** and press the **FUNCTION** key until the **Program Printout** menu item appears in the display. The default value of this item is zero or OFF.



2. Press the **NO** key to change the value in the display to "1" or ON.



3. With "1" flashing in the display, press the **YES** key. The "1" will cease to flash, the ribbon carriage will cycle, and all programs in the CP-3000 will momentarily appear in the display.



4. Insert a time card. All **Basic Programming** information will be printed on the time card. On Model A051, the information will be printed in red ink.

```

PROGRAM INFO
CP 3000
11=99 12=11/22
13=13:35
21=02:00
22=04/04 23=10/31
38=20 39=16
41=1 42=1
43=1 44=2
45=1 46=2 47=1
51=08 52=0

```

5. If you have programmed one or more **Weekly Programs**, insert another time card (or the reverse side of the one used in step 4) to obtain a printout. Up to sixteen **Weekly Programs** are printed on a card.

```

PROGRAM INFO
STP DAYS TIME SIGNALS C/L CLR
01 -2-45-- 8:27 R1 BL
02 -2-45-- 10:12 BZ RE

```

6. To stop printing at any time, press and hold either the **NO** or **YES** key. Only the currently inserted time card will be printed on, and the remainder of the programming data will not be printed.
7. When printing is completed, the display will automatically move to the next menu. Exit the **Program Mode** by setting the **Mode Switch** to **NORMAL**.

Editing Weekly Programs

1. Obtain a printout of the current **Weekly Programs**.
2. Mark on the printout the desired **Weekly Program** that you want to change.
3. Enter the **Program Mode** and press the **FUNCTION** key until the **Weekly Program** menu item appears in the display.
4. Press and hold the **YES** key until the desired program number appears. To move to previously numbered **Weekly Programs**, press and hold the **NO** key.
5. Change the **Weekly Program** as desired. For the changes to be in effect, you must cycle through the sequence of displays, and save the data entered.
6. After saving the program, press the **FUNCTION** key to move to the **Program Printout** menu item and print out a copy of the program to check.

Adding Additional Weekly Programs

1. Obtain a printout of the current **Weekly Programs**.
2. Mark the last **Weekly Program** on the printout.
3. Enter the **Program Mode** and press the **FUNCTION** key until the **Weekly Program** menu item appears in the display.
4. Press and hold the **YES** key until an empty **Weekly Program** appears in the display. The program number should be the last program number on the printout + 1.
5. Set the program as desired. For the changes to be in effect, you must cycle through the sequence of displays, and save the data entered.
6. After saving the program, press the **FUNCTION** key to move to the **Program Printout** menu item and print out a copy of the program to check.

Deleting a Weekly Program

1. Obtain a printout of the current **Weekly Programs**.
2. Mark on the printout the desired **Weekly Program** that you want to delete.
3. Enter the **Program Mode** and press the **FUNCTION** key until the **Weekly Program** menu item appears in the display.
4. Press and hold the **YES** key until the desired weekly program number appears. To move to previously numbered **Weekly Programs**, press and hold the **NO** key.
5. Press the **NO** key to delete all days of the week that the program was scheduled for.
6. All the objects in the program will flash in the display.
7. Press the **YES** key to delete this program. The remainder of the programs in the CP-3000 will automatically have their program number moved down one to fill the empty space left by the program that was just deleted. For example, if program number seven was deleted, program number eight will now be program number seven.
8. After saving the program, press the **FUNCTION** key to move to the **Program Printout** menu item and print out a copy of the program to check.

Chapter 5: Maintenance

Service

With the exception of the ribbon and fuses, there are no user-serviceable parts in the time recorder. Do not attempt to service/disassemble the time recorder other than prescribed in this manual.

Exterior

Gently wipe the exterior of the unit with a soft cloth dampened with water and a neutral detergent. Do not use thinner, benzine, or insecticides.

Fuse Replacement

There are two fuses used in the CP-3000. The main fuse is a 250 V F2A (Fast Acting) fuse. The second fuse, which protects the power supply, is a 250 V F4A (Fast Acting) fuse. To replace either fuse, perform the following:

1. Disconnect the power cord from the power source.
2. Remove the top cover and the front cover.
3. Disconnect the battery.
4. Lift up the insulator flap and locate the fuse you wish to replace.

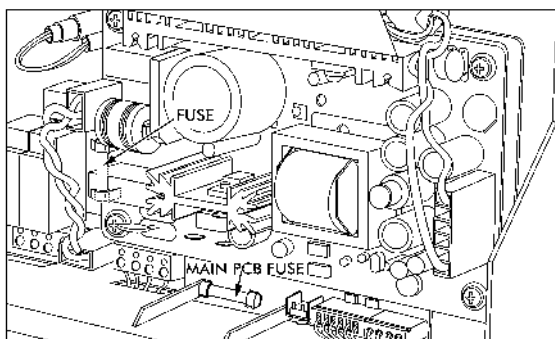

5. Replace the desired fuse ***only with one of the same type and rating.***
6. Connect the battery and install the front cover.
7. Connect the power cord to the power source.
8. Program the correct time and date.
9. Set the **Mode Switch** to **NORMAL** and install the top cover.

Ribbon Replacement

The ribbon should be replaced when the imprint of the time card appears light or when the following message appears in the display:



Always use Amano approved ribbons. Non-Amano ribbons bind in the printer carriage, and produce weak quality prints and ink residue on print head, rollers, and the time card.

Note: Extreme care should be used when removing the ribbon. Verify that the **Mode Switch** is set to **PROGRAM** before attempting to remove the ribbon. Forcing the ribbon out of the ribbon carriage may damage the ribbon guide.

To replace the ribbon:

1. Remove the top cover.
2. Set the **Mode Switch** to **PROGRAM**.
3. Grasp the front panel from the bottom and flip it up.
4. Using two fingers, press the two white release tabs down and towards the case, and while holding them, remove the ribbon.

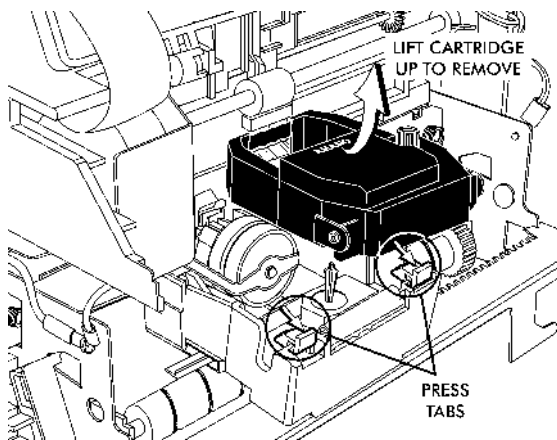

5. Insert a new ribbon between the ribbon guide and the printer head.

6. Press the ribbon down until it clicks into place. Turn the knob clockwise to remove any slack in the ribbon.

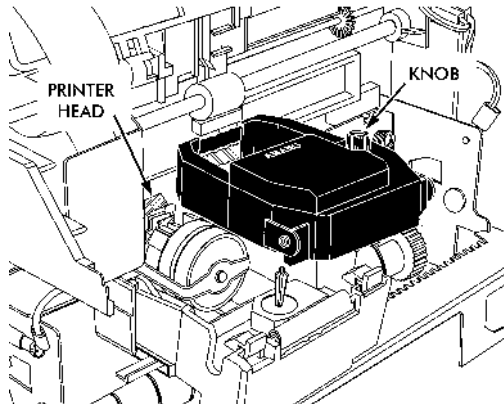

7. Rotate the front panel down until it clicks in place.
8. Set the **Mode Switch** to **NORMAL**.
9. Insert a time card into the card throat to check the printing quality and to confirm that you have installed the ribbon properly.
10. Replace the top cover.

Chapter 6: Troubleshooting

Introduction

If your CP-3000 should fail to operate properly, you should perform the following to determine the cause:

- Visually inspect the unit
- Obtain a print out of programmed data and verify it
- Check that AC power is connected
- Inspect the fuses, if either is blown, replace it
- Check the condition of the time card, if it is dirty or damaged, it must be replaced
- Run the specified test in the Diagnostics menu
- Reinitialize the unit
- Perform a Reset (Clear All) to reset the unit to defaults

If, after performing the above, you still are unable to resolve the problem or feel that your unit requires servicing, contact your local Amano dealer.

General Problems

Signal 1

If you are experiencing a problem with the relay signal circuit (Model A051 and A056 only), you should perform the following:

- Verify that the connections to **CN7A/CN7B** are correct
- Verify that the external device is working properly
- Verify that the maximum load is not exceeded
- Check to see that the appropriate surge absorber is properly connected to the external device
- Check all wiring
- Inspect the fuses on the CP-3000. If either is blown, replace it
- Obtain a printout of programmed data in your CP-3000. Verify that **Signal 1** is correctly programmed in the **Weekly Program**
- Run the Signal 1 Test from the **Diagnostics** menu to check if the **Signal 1** relay is operating properly. If it is not, contact your local Amano dealer

Foreign Object or Material

Only a time card should be inserted into the unit. If foreign objects or materials get inside the CP-3000, you must disconnect the AC power and the battery, and remove the foreign objects.

Programming

If you suspect a programming problem or the imprint position (margin) is incorrect, it is recommended that you obtain a printout of the programmed information as described in **Chapter 4** and troubleshoot the programmed data, or perform a Reset (Clear All) to reset the unit to defaults.

If you are unable to resolve the problem, please contact your local Amano dealer.

Key Failure

If you suspect that one of the keys has failed, you should run the Key Test in the Diagnostics menu.

Audible Beeps

The time recorder is equipped with an audible alarm that “beeps”. The beeps will vary in duration and corresponding meaning.

Action	Cause
One Beep	Time Card improperly inserted
Two Beeps	<ul style="list-style-type: none"> • No more print space on Time Card, column full • Time Card was removed too soon or is too short
Continuous Beep	LCD Display not connected or not functioning

Error Messages

There are nine possible error messages that can appear in the display. These messages are divided into two types, those that will return to normal operation once displayed (Err 0 thru Err 5), and those that require immediate attention (Err 6 thru Err 9).

Err 0 thru Err 5

When one of the following errors occur, the CP-3000 will display the error message and may beep. After the beeps, the message will disappear and the unit will return to normal operation. These messages are used as warnings that there may be a problem that does not require immediate attention.

Leap Year Error

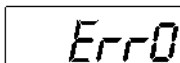

February 29th is programmed for a non-leap year. If this occurs, the date will automatically be changed to March 1st of that year. Please check your programmed year, month and date. This message can also be cleared by performing a Reset (Clear All).

Printing or Ribbon Error



The time card sensors could not detect the **Column Position Block**. Possible reasons are:

- The imprint quality (black color) is poor or too light. Replace the ribbon cassette.
- No ribbon cassette is inside the machine. Install a ribbon cassette.
- The ribbon cassette is not seated correctly in the printer carriage. Reinstall the ribbon cassette.
- The red color is active in front of the dot head. This is due to normal interference between slider and printer carriage. Push slider to normal position.
- Printer or printer carriage is damaged. Contact your local Amano dealer.

- A non-Amano ribbon was used. Always use Amano approved ribbons: non-Amano ribbons bind in the printer carriage, produce weak quality prints and ink residue on print head, rollers, and time card.
- The slider on the printer carriage is not moving correctly due to a missing black plastic bushing in the small hole of the right printer frame. Contact your local Amano dealer.
- The card throat width is set too narrow for the card type used. The card throat must be set to 0.5 mm greater than the card width.
- The time card you are using is too narrow for the imprint. Remove characters from the imprint or use a wider card.
- There is dirt, oil, dust, or ink residue on the surface of the time card or the time card surface is too rough for the time card sensor to detect the **Column Position Block**. Replace the card.
- The background color of the time card is too dark.

Time Card Error

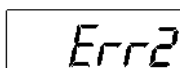

When this message is displayed, printing will stop immediately. Possible reasons for this error can be:

- The time card was pushed or pulled when fed into the card throat or during the printing cycle
- The time card feed mechanism or time card sensors are damaged

Imprint/Card Size

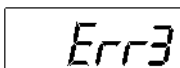

This message is displayed when the time card setting has been changed in **Program Mode**. You must perform a Reset (Clear All) to reset to the default card type.

Weekly Program



Possible reasons for this error message are:

- The time card setting has been changed in **Program Mode**
- Duplicate times have been scheduled in the **Weekly Program**

You must perform a Reset (Clear All) to reset to the default card type and clear the **Weekly Program**.

Overheat Protection

To prevent overheating of the card feed and printing motors and a quick and high discharge of the battery, the CP-3000 is provided with an internal counter for the number of imprints. When you print too many times within a short time period, the recorder will refuse to accept new cards, beep, and may display the following message:

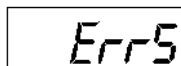

If this occurs, please take the time card out of the card throat and wait for several minutes.

Err 6 thru Err 9

These error messages will remain in the display until the problem is resolved and the CP-3000 is restarted by pressing any key with the message in the display. When displayed, the time and date will be maintained (unless your AC power is disconnected) as in normal mode and no programming data will be lost.

Card Stuck

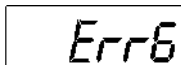

This error occurs when a non-standard time card shape is used or the time card is forced into the card throat. In either case, the time card sensors detect the presence of the time card, but the unit is unable to flush out the card. The time card has to be removed manually to resolve this problem.

Insufficient Power

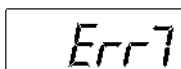

This message is displayed when there is not enough power from the AC power supply to start up the feed or print motors. To resolve this error, perform the following:

- Check the condition of the fuses, replace if necessary
- Check the connections and condition of the battery.
- Re-initialize the unit and charge the battery by allowing the unit to be connected to AC power and stand idle for 24 hours. If this message still occurs, replace the battery.
- The normal life-span of the battery used is three to five years. If it falls outside of that range, you should replace the battery.

Blank Display



When this condition occurs, the CP-3000 will also emit a continuous beep. If possible, perform the **LCD Test** in the **Diagnostics** menu. If this condition persists, contact your local Amano dealer.

Eprom

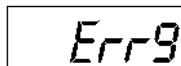

If this message is displayed, please contact your local Amano dealer.

Display Related Problems

Low Battery

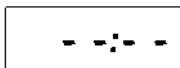

This display indicates that the battery is too weak to power-up the system. If AC power is connected during this condition, the CP-3000 will try to restart automatically once every ten minutes from the moment the low battery condition was detected. If AC power is not present, the indication will remain in the display and the unit will not recover automatically.

During this low battery display indication, the time and date will be maintained, and the number of prints made should be kept to a minimum. If AC power is connected, there will be no loss of programmed data.

If there is no damage to the battery, the battery can be recharged by the AC power supply, and the time unit will restart by itself. Please allow the CP-3000 24 hours to recharge the battery completely.

Power Failure

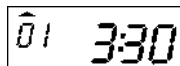

A blinking LED and constant colon in the display indicates an AC power failure. When this occurs, the operation of the CP-3000 is taken over by the internal battery.

If AC power is connected and working, and the display indicates a power failure, contact your local Amano dealer.

Inaccurate Clock

The clock frequency is factory set. If you feel that your clock is inaccurate, please contact your local Amano dealer.

LED's Not Functioning

If the LED's fail to function on the front panel, run the **LED** test in the **Diagnostics** menu. If the problem is not resolved, contact your local Amano dealer.

Hour Change

If the time displayed is off by an hour (either up or down), one of the following may have occurred:

- The programmed DST settings are incorrect
- the **YES** or **NO** key was inadvertently pressed while setting the **Mode Switch** from **NORMAL** to **PROGRAM**

Slave Master



If this indication should occur (minutes blinking), enter the **Program Mode** and set the **Master Clock** menu item to zero.

Card Feed Problems

Card Refused

- Check whether the column of your time card is already completely filled with imprints. If all positions are already occupied by an imprint, two beeps will sound, and the card will be rejected without making an imprint.
- Check the condition of the time card. If there is dirt, oil, dust, or ink residue on the card, the time card sensors cannot read the **Column Position Block**.
- Verify the imprint position. If the **Column Position Block** is positioned on artwork or a column line, the time card sensor will read this as a column full condition.
- A non-Amano ribbon was used. Always use Amano approved ribbons, non-Amano ribbons bind in the printer carriage, and produce weak quality prints, and ink residue on print head, rollers, and time card.
- The background color of your time card is too dark

Card Cannot Enter or Card Blocked

When you insert a time card into the card throat, the feed motor will grasp it and pull it down to be printed. The feed motor will attempt to grasp the card a maximum of three times. If the third attempt fails, a long beep will sound, the feed motor will shut off, and the card must be manually removed from the card throat.

If a card is blocked or stuck inside the card throat after the imprint has been printed, the feed motor will attempt to flush out the card a maximum of three times. If the card is still inside the card throat after the third attempt, the feed motor will shut down, leaving the card inside the unit. After a minute change on the display or when the user presses one of the keys, the CP-3000 will automatically retry to flush out the card. If the card is unable to be flushed out by the feed motor, it must be manually removed.

Both of these conditions are symptoms of the card throat width being too narrow. The card throat width adjustment must be done at both the upper and lower positions, each having a gap of 0.5 mm (0.0197") between the card and the card guide.

Card Refused, Date and Time in Display

If a time card is inserted into the card throat, refused, and a beep sounds, the time card is too short. The time card sensors compare the top margin of the time card with the imprint position. If it can not reach this imprint position, the unit will beep and refuse the card.

Imprint Problems

Overprint

The column position block in the imprint is used by the CP-3000 to prevent overprinting. If your CP-3000 is overprinting, any one of the following may be the cause:

- The time card was pushed, pulled, or moved during the printing cycle causing the time card sensors to misinterpret the **Column Position Block**
- The card throat pocket width is too wide
- The quality of the ribbon is poor. The system can not detect a weak column position block.
- A non-Amano ribbon was used. Always use Amano approved ribbons: non-Amano ribbons bind in the printer carriage, produce weak quality prints and ink residue on print head, rollers, and time card.
- The background color of the time card is too dark
- The surface of the time card is too rough or there is dirt, oil, dust, or ink residue on the card

Imprint Position Wrong

If your CP-3000 is functioning normally, but the position of the imprint is incorrect, perform the following:

- Obtain a print out of the programmed data from the CP-3000. Verify that your settings are correct.
- Verify that the programmed date and time are correct.
- The card throat width is incorrect.
- A non-Amano ribbon was used. Always use Amano approved ribbons: non-Amano ribbons bind in the printer carriage, produce weak quality prints and ink residue on print head, rollers, and time card.
- The feed rollers may be damaged or require cleaning. Contact your local Amano dealer.

Wrong Color Printed

The model A051 and A056 versions of the CP-3000 has the ability to print in red or black ink. When the **Mode Switch** is set to **NORMAL**, the default ink color is black, and the color of ink printed is determined by the settings in the **Weekly Program**. When the **Mode Switch** is set to **PROGRAM**, the CP-3000 will print in red. If the wrong color is being printed by your CP-3000, please perform the following:

- Verify that the **Mode Switch** is in the correct position for the current operation
- Obtain a print out of the programmed data from the CP-3000. Verify that your **Weekly Program** settings are correct.
- The red color is active in front of the dot head. This is due to normal interference between slider and printer carriage. Push slider to normal position.
- Printer or printer carriage is damaged. Contact your local Amano dealer.
- The slider on the printer carriage is not moving correctly due to a missing black plastic bushing in the small hole of the right printer frame. Contact your local Amano dealer.
- The ribbon cassette is not seated correctly in the printer carriage. Reinstall the ribbon cassette.
- Run the **Color Change Test** in the **Diagnostics** menu.
- Printer or printer carriage is damaged. Contact your local Amano dealer.

Weak or Light Printing

Please refer to **Printing or Ribbon Error Message, Err1** section of this chapter for troubleshooting weak or light printing problems.

Diagnostics

The **Diagnostics** menu is used to run specific diagnostic routines for troubleshooting and determining the condition of your CP-3000.

The **Diagnostics** menu is accessed by entering the **Program Mode**, and pressing the **FUNCTION** key until the LED Test menu item appears in the display and the last LED indicator is illuminated.



The general guidelines for the **Diagnostics** menu are as follows:

- Each test is indicated by a specific number (refer to the **Programming Guide**) flashing in the display
- To select and start a test, press the **YES** key
- To stop a test press the **YES** key again. A beep will sound and the test number will flash in the display
- Press the **NO** key to move to the next test
- Press the **FUNCTION** key to leave the **Diagnostics** menu

LED Test

1. If you have not already done so, enter the **Program Mode** and press the **FUNCTION** key until the **LED Test** menu item appears in the display.
2. Press the **YES** key to select and start the test. The test number will cease to flash in the display, and the LED indicators will illuminate one at a time from left to right.
3. Press the **YES** key to stop the test. A beep will sound and the test number will flash in the display.
4. Press the **NO** key to move to the next test or exit the **Diagnostic** menu by pressing the **FUNCTION** key, or by exiting the **Program Mode**.

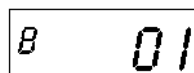

Mode and Keys Test

1. If you have not already done so, enter the **Program Mode** and press the **FUNCTION** key until the **LED Test** menu item appears in the display.
2. Press the **NO** key. The **Mode and Keys Test** menu item will appear in the display.
3. Press the **YES** key to select and start the test. The test number will cease to flash in the display, and the first LED indicator (on the left side of the front panel) will illuminate
4. Slide the **Mode Switch** to **NORMAL**. The LED indicator should turn off.
5. Slide the **Mode Switch** to **PROGRAM**. The LED indicator should illuminate. Repeat this sequence several times.
6. To test the keys, set the **Mode Switch** to **NORMAL**. The LED indicator should turn off.
7. Press the **FUNCTION** key, the second LED indicator will illuminate.
8. Press the **YES** key, the third LED indicator will illuminate.
9. Press the **NO** key, the fourth LED indicator will illuminate. Repeat this sequence several times.
10. Set the **Mode Switch** to **PROGRAM** and press the **YES** key to stop the test. A beep will sound and the test number will flash in the display.
11. Press the **NO** key to move to the next test or exit the **Diagnostics** menu by pressing the **FUNCTION** key, or by exiting the **Program Mode**.

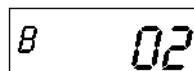

LCD Test

1. If you have not already done so, enter the **Program Mode** and press the **FUNCTION** key until the **LED Test** menu item appears in the display.
2. Press the **NO** key twice. The **LCD Test** menu item will appear in the display.
3. Press the **YES** key to select and start the test. The test number will disappear and all the segments of the LCD display will flash.
4. Press the **YES** key to stop the test. A beep will sound and the test number will flash in the display.
5. Press the **NO** key to move to the next test or exit the **Diagnostics** menu by pressing the **FUNCTION** key, or by exiting the **Program Mode**.



Eprom Test

1. If you have not already done so, enter the **Program Mode** and press the **FUNCTION** key until the **LED Test** menu item appears in the display.
2. Press the **NO** key four times. The **Eprom Test** menu item will appear in the display.
3. Press the **YES** key to select and start the test. The test number will cease to flash in the display, and the first LED indicator (on the left side of the front panel) will illuminate. After three seconds, the first LED will turn off, the second LED will illuminate and the size of the Eprom will be in the display.

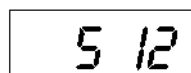
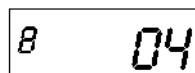

4. Press the **YES** key to stop the test. A beep will sound and the test number will flash in the display.



5. Press the **NO** key to move to the next test or exit the **Diagnostics** menu by pressing the **FUNCTION** key, or by exiting the **Program Mode**.



Buzzer Test

1. If you have not already done so, enter the **Program Mode** and press the **FUNCTION** key until the **LED Test** menu item appears in the display.



2. Press the **NO** key five times. The **Buzzer Test** menu item will appear in the display.



3. Press the **YES** key to select and start the test. The test number will cease to flash in the display, and the **Buzzer** will sound for a maximum of eight beeps.

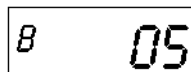

4. Press the **YES** key to stop the test. A beep will sound and the test number will flash in the display.



5. Press the **NO** key to move to the next test or exit the **Diagnostics** menu by pressing the **FUNCTION** key, or by exiting the **Program Mode**.



Signal 1 Test

1. If you have not already done so, enter the **Program Mode** and press the **FUNCTION** key until the **LED Test** menu item appears in the display.
2. Press the **NO** key six times. The **Signal 1 Test** menu item will appear in the display.
3. Press the **YES** key to select and start the test. The test number will cease to flash in the display and you will hear a clicking sound as the relay contacts open and close.
4. Press the **YES** key to stop the test. A beep will sound and the test number will flash in the display.
5. Press the **NO** key twice to move to the next test or exit the **Diagnostics** menu by pressing the **FUNCTION** key, or by exiting the **Program Mode**.



Color Change Test

1. If you have not already done so, enter the **Program Mode** and press the **FUNCTION** key until the **LED Test** menu item appears in the display.
2. Press the **NO** key eight times. The **Color Change Test** menu item will appear in the display.
3. Press the **YES** key to select and start the test. The test number will cease to flash in the and you will hear a clicking sound as the color change solenoid is turned on and off.
4. Press the **YES** key to stop the test. A beep will sound and the test number will flash in the display.
5. Press the **NO** key twice to move to the next test or exit the **Diagnostics** menu by pressing the **FUNCTION** key, or by exiting the **Program Mode**.



Model ID

1. If you have not already done so, enter the **Program Mode** and press the **FUNCTION** key until the **LED Test** menu item appears in the display.



2. Press the **NO** key ten times. The **Model ID** menu item will appear in the display.



3. Press the **YES** key to select this item. The display will indicate the model number of your CP-3000.

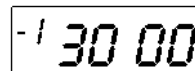

4. Press the **YES** key. A beep will sound and the test number will flash in the display.



5. Exit the **Diagnostics** menu by pressing the **FUNCTION** key, or by exiting the **Program Mode**.

Appendix

Weekly Programming Chart

The following charts are provided to assist you in creating **Weekly Programs** for your CP-3000.

Program No.	Moment							Object			
	Days						Time HH:MM	1. Buzzer 0: Off 1: On	2. Signal 1 0: Off 1: On	3. Signal 2 0: Off	5. Color 0: No Change 1: Black 2: Red
	1	2	3	4	5	6					
01							:				
02							:				
03							:				
04							:				
05							:				
06							:				
07							:				
08							:				
09							:				
10							:				
11							:				
12							:				
13							:				
14							:				
15							:				
16							:				
17							:				
18							:				
19							:				
20							:				
21							:				
22							:				
23							:				
24							:				
25							:				
26							:				
27							:				
28							:				
29							:				
30							:				
31							:				
32							:				
33							:				
34							:				
35							:				
36							:				
37							:				
38							:				
39							:				
40							:				

(Chart continued on next page)

Program No.	Moment							Object				
	Days							Time HH:MM	1. Buzzer 0: Off 1: On	2. Signal 1 0: Off 1: On	3. Signal 2 0: Off	5. Color 0: No Change 1: Black 2: Red
	1	2	3	4	5	6	7					
41							:					
42							:					
43							:					
44							:					
45							:					
46							:					
47							:					
48							:					
49							:					
50							:					
51							:					
52							:					
53							:					
54							:					
55							:					
56							:					
57							:					
58							:					
59							:					
60							:					
61							:					
62							:					
63							:					
64							:					
65							:					
66							:					
67							:					
68							:					
69							:					
70							:					
71							:					
72							:					
73							:					
74							:					
75							:					
76							:					
77							:					
78							:					
79							:					
80							:					





Central Time Clock

Since 1931

5-23 50th Avenue | Long Island City, NY 11101

P: 718.784.4900 F: 718-472-9491

www.centraletimeclock.com